



Vespa G.S.

OPERATION AND MAINTENANCE



Vespa G.S.

OPERATION AND MAINTENANCE

scooterhelp.com



NOTICE

In order to keep their VESPA G. S. in perfect running conditions and not to void the guarantee offered by the contract, customers should always have their machines repaired by sale agents or authorized service stations. Demand original **PIAGGIO** spare parts exclusively.

Special care should be taken in regard to fuel mixture which should result of normal but first class gasoline and oil of make, grade and in the amount prescribed in this booklet, page 22. Avoid use of additives and vegetable oil.

INDEX OF MAIN DIRECTIONS

| | | | |
|--------------------------|---------|---|---------|
| Fuel Supply | page 11 | Checking oil level | page 18 |
| Gear change troubles | " 15 | Cleaning and adjusting the sparkplug | " 20 |
| Slow running adjustment | " 15 | Assembling the sparkplug | " 20 |
| Assembling the wheels | " 15 | Battery service | " 21 |
| Tyre pressure | " 16 | Lubrication | " 22 |
| Running-in | " 17 | Fault finding | " 22 |
| Cleaning the scooter | " 18 | | |
| First use of the scooter | " 18 | | |





Fig. 1 - scooter VESPA G. S.



MAIN SPECIFICATION

Fuel consumption at economic speed:

3 l. to 100 Km. $\left\{ \begin{array}{l} 80 \text{ miles per USA gal.} \\ 95 \text{ miles per imp. gal.} \end{array} \right.$

Max speed . . . 100 Km/h
(62 m. p. h.)

Wheel base . . . 1180 mm. (46.4 in)

Max width on handlebars . . . 700 " (27 ")

Max length of the scooter . . . 1700 " (67 ")

Max height . . . 1050 " (41.3 ")

Ground clearance . 285 " (11.2 ")

Minimum turning circle . . . 1400 " (55 ")

Weight (unladen) approx . . . 100 Kg. (220 lbs)

Engine: Single cylinder, two-stroke, with reverse flow scavenge and high volumetric efficiency. Flat cast iron cylinder and pressure die cast, special aluminium alloy cylinder head.

High strength, steel con. rod connected, through a row of rollers, with the crankshaft which is built of three parts.

Bore 57 mm. (2.24")

Stroke 57 mm. (2.24")

Displacement . 145.55 cc. (8.82 cu in.)

Compression ratio 7 to 1

Starting: By means of kickstarter, right hand side of scooter.

Transmission: Directly from engine to rear wheel through clutch, cush drive and gear box.

scooterhelp.com



- 1 - Fuel cock
- 2 - Throttle control grip
- 3 - Clutch control lever
- 4 - Front brake lever
- 5 - Horn
- 6 - Horn button
- 7 - Dimmer switch
- 8 - Gear change twistgrip
- 9 - Contact key
- 10 - Rear brake pedal
- 11 - Kickstarter
- 12 - Choke rod

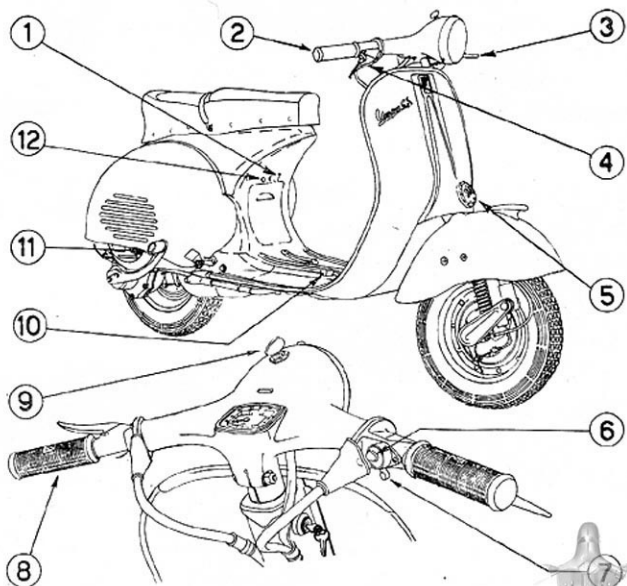

Fig 2 - VESPA controls



Gear change: 4-speed drive with mesh gears in oil bath. Its adjustable twistgrip control is coupled with that of the clutch, on left hand side of handlebars (fig. 2).

Clutch: Wet type; steel plates with cork inserts. Control by lever, on left hand side of handlebars, and adjustable cable.

Ignition: By 6-pole flywheel magneto. Separated ignition coil with primary circuit fed by another coil inside the flywheel magneto.

Lighting and horn: By flywheel magneto, with a. c. directly feeding head lamp (double filament bulb, 6 v, 25/25 w), and tail lamp, 6 v, 5w, when the switch is in position "2".

The town light (6 v, 3 w), tail lamp, STOP light and horn are fed by the 12 Ah battery, which is constantly re-charged through a metallic rectifier and impedance, when the key of the switch is in either position "0" or "1" (see Fig. 3).

Frame: of special, thick steel sheet, pressed and spot welded, with streamlined monocoque type structure.

Suspension: Front: stub axle and swinging hub with variable rate coil spring and double action hydraulic damper. Rear: swinging bracket for engine and wheel, with variable rate coil spring and co-axial double action hydraulic damper.

scooterhelp.com



- 1 - Main beam
- 2 - Dipping light
- 3 - Horn button
- 4 - Dimmer switch with horn button
- 5 - Violet
- 6 - Brown
- 7 - Inside view of head lamp
- 8 - Head lamp earthing cable (with)
- 9 - Pink
- 10 - White
- 11 - Bleu
- 12 - To the low tension socket (red)
- 13 - To the horn (green)
- 14 - To the low tension socket (yellow)
- 15 - To the rectifier (violet)
- 16 - To the tail lamp (black)
- 17 - Impedance 1.8-1.85 Ohm at 1.5 A, 50 Hz Resistor 0.5-0.52 Ohm
- 18 - To the horn (pink)
- 19 - Four-position main switch
- 20 - Town light, 6v, 3w
- 21 - Double filament bulb, 6v, 25/25 w
- 22 - Horn
- 23 - Cut-out, earth
- 24 - Running position
- 25 - Head lamp and tail lamp
- 26 - Light off
- 27 - Town light and tail lamp
- 28 - Rectifier, 6 v, 2 A
- 29 - To the main switch
- 30 - Sparkplug
- 31 - From positive pole of battery (red)
- 32 - To the STOP light (bleu)
- 33 - STOP switch
- 34 - Low tension socket and earthing tag
- 35 - Ignition coil
- 36 - To the flywheel magneto
- 37 - Black
- 38 - Red
- 39 - Yellow
- 40 - To the sparkplug
- 41 - To the main switch
- 42 - Tail lamp 6 v, 5w, with STOP light 6v, 15w
- 43 - Negative pole of battery (black)
- 44 - Battery, 6v, 12 Ah

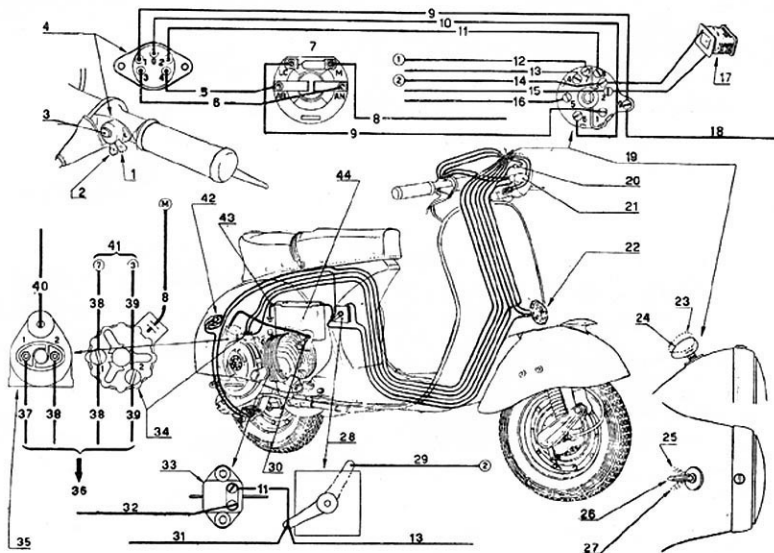

Fig. 3 - Scheme of electric wiring

- 39 - Yellow
- 40 - To the sparkplug
- 41 - To the main switch
- 42 - Tail lamp 6 v, 5w, with STOP light 6v, 15w
- 43 - Negative pole of battery (black)
- 44 - Battery, 6v, 12 Ah



Brakes: Expanding type with cooling ribs; cable control. Front: lever on right hand side of handlebars. Rear: pedal on right hand side of floorboard.

Wheels: Of pressed steel sheet, interchangeable and easily removable, following normal car practice. Tyres: dia. 441 mm. (3.50x10 in.).

Fuel tank: With sediment bowl and three-way cock: «open» - «closed» - «reserve». Total capacity: 12 liters (3.17 USA gals.; 2.64 imp. gals.) Emergency reserve: 1.2 liters (.31 USA gals.; .26 imp. gals.).

Central stand. A two-leg stand, easy to operate, is arranged under the floor-

board. Two strong return springs hold it in contact with the floorboard and keep it from vibrating while the scooter is being ridden.

Speedometer. The speedometer has its housing in the upper half of the handlebars support, and adds to the performance and appearance of the scooter. It is driven by the front wheel, the flexible shaft being completely enclosed in the steering column.

Steering lock. A suitable security lock is arranged on the frame, near the handlebars. Turning the key anticlockwise and the handlebars to the left, the lock engages the lugs welded on the steering column, so that the ma-

scooterhelp.com



chine can only turn around. Turn the key clockwise and the handlebars back to normal position for releasing the steering system (see fig. 4).

Important. We recommend **not** to lubricate the steering lock even if it does not function properly.

Do not attempt to ride the machine unless the key is in, and remains in, the lock and the handlebars move freely.

Tool kit. 1 fuor-end box spanner (11-14-21-22 mm.) 2 single open-end spanners (7-8 mm), 1 double open-end spanner (11-14 mm.), 1 screwdriver, 1 fly-wheel and clutch removal tool.

These hand tools are contained in a

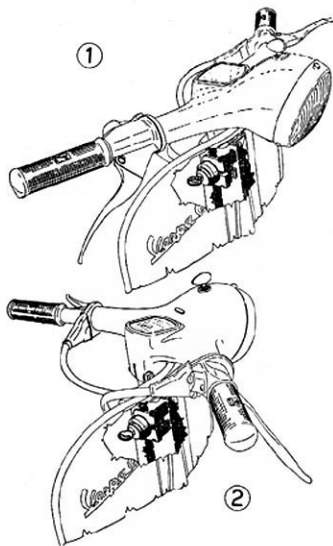

Fig- 4 - Steering lock

1. - Running position

scooterhelp.com



canvas roll which is placed in the left wing together with this booklet, the test card and the inflator.

Accessories. On request the **Vespa G.S.** scooter can be equipped with **spare wheel and support**. The wheel support can be secured to the hole in the middle of the longeron. It is very simple and holds the wheel in a vertical position, quite easy to reach (see Fig. 5).

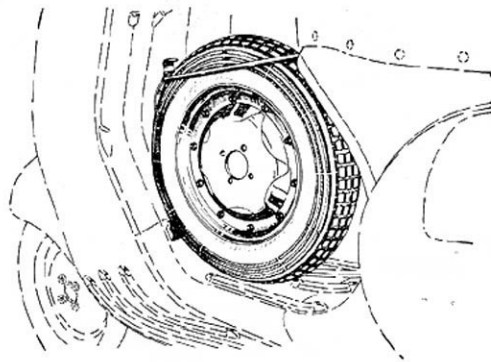

Fig. 5 - Spare wheel



Notwithstanding the noteworthy features and wide field of use of the **Vespa G.S.**, no particular dealing is required for its **operation**, nor skilled personnel for its **maintenance**.

The tasks can be quite well carried out by any customer, even unexperienced, by carefully following some general rules.

OPERATION

Fuel supply. The filling cap can be reached by depressing the button under the dual seat cover and swinging the seat towards the front (see Fig. 6). Fuel mixture should be composed of gasoline and oil **Essolube 30**, in following proportion: 90 cc. of oil to 1 liter

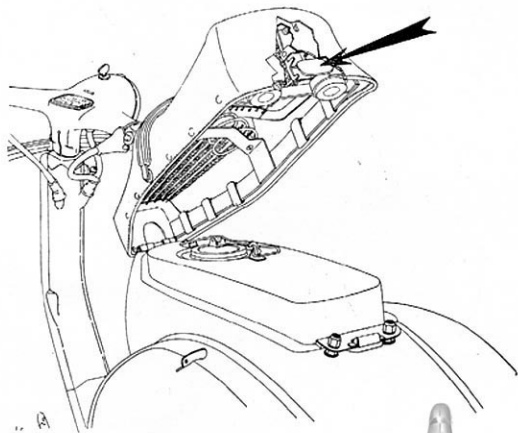

Fig. 6 - Catch on dual seat



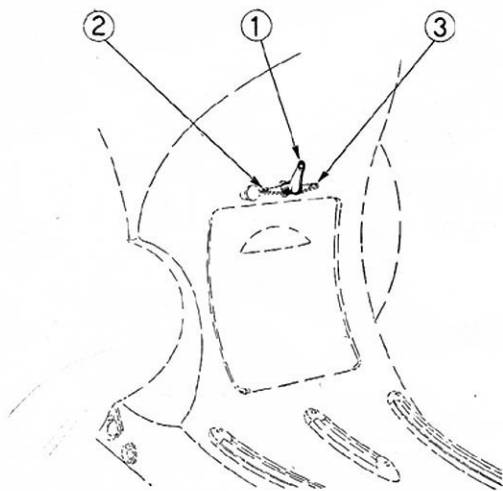

Fig. 7 - Fuel tap positions
1. Open - 2. Reserve - 3. Closed

of gasoline for running-in (2000 Km - 1200 miles), and 65 cc. afterwards.

N.B. - Customers may also ask for ESSO MIX, (respectively 8% for the first 2000 Km. and 6% afterwards).

Notice. We recommend to use good quality, standar grade car gasoline, and to mix oil with gasoline thoroughly. Keep the breather of filling cap clean. Carefully follow running-in directions.

Starting the engine: Open the fuel tap (see on fig. 7 the three positions, of the fuel tap: open, closed, reserve), put the gear box in neutral (see Fig. 8), insert the key completely into the switch on top of the head lamp, keep the



throttle in slow running position, kick the starting lever.

In case of starting troubles, specially with cold engine, pull the choke rod on the side of the fuel cock (see Fig. 2) and operate the kickstarter again. Once the engine started, push the choke rod back.

Setting the machine in motion. Let the engine idle, depress the clutch and turn the gear change twistgrip so that the line engraved on it coincides with the figure «1» (1st gear) engraved on handlebars (see fig. 8). Now let in the clutch gently, while opening the throttle gradually to set the machine in motion.

Gear change. After reaching the re-



Fig. 8 - Gear change

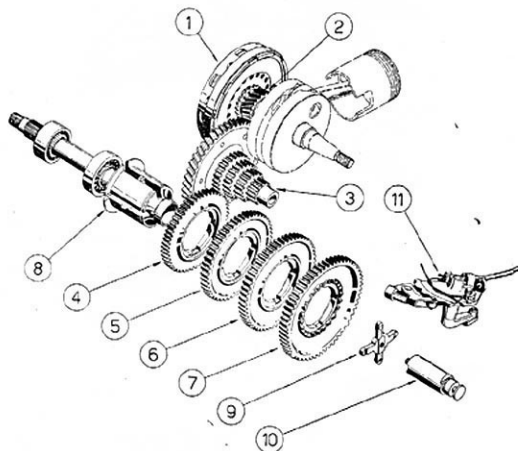

Fig. 9 - Drive system

- 1. Clutch - 2. Clutch pinion - 3. Cush gear - 4. 4th gear pinion
- 5. 3rd gear pinion - 6. 2nd gear pinion - 7. 1st gear pinion
- 8. Gear shaft - 9. Selector - 10. Selector stem - 11. Gear shifter.

quired speed in 1st gear, close quickly the throttle, depress the clutch and turn the gear change twistgrip so that the engraved line is opposite figure «2» (2nd gear); let in the clutch and open the throttle gradually. Repeat this procedure for changing into 3rd and then into 4th gear.

Change down by a similar procedure. After exercising a little, you will find that gears can be changed without using the clutch lever at all; this won't damage the gear box (see the drive system on fig. 9).

When you reduce the speed of your machine, change down with no delay.

NOTICE: Do not turn the gear change

scooterhelp.com



twistgrip while the engine is not running.

As soon as gear change troubles arise, particularly when the control becomes hard, customers should have their machines adjusted by a sale agent or authorized service station.

Slow running adjustment. No hand tool is required for this job; idling revs can be raised by simply tightening the screw which presses on carburettor cover and vice-versa.

Stopping the engine. Pull upwards the key in the switch on top of the head lamp. This will leave the cylinder full of fuel vapours, and the next start will be much easier.

Tyres: The wheels are interchangeable, i. e. they can be assembled either in front or rear, provided, of course, that they are inflated to the pressures respectively prescribed (see below).

When a flat tyre is to be replaced, unscrew the four nuts which secure the wheel to the brake drum, pull the wheel sideways off the studs, repair it or fit the spare wheel on.

Notice. Make sure that the spring washers are present when re-assembling the wheel; tighten the nuts diagonally and evenly.

For removing the inner tube, let the air out first, then unscrew the ten nuts on the wheel, so that the two halves



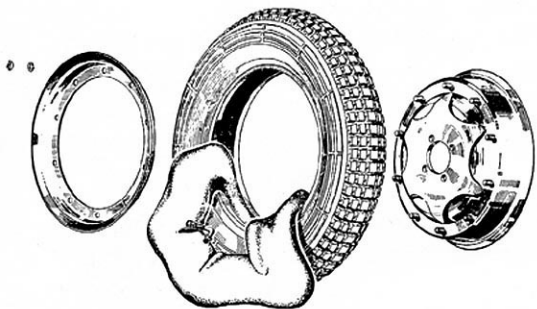

Fig. 10 - Removal of inner tube

of the rim will fall apart (see fig. 10). Tyre pressure should be:

- front wheel : 1.2 Kg/cm² (17 psi) in all cases.
- rear wheel : 1.75 Kg/cm² (25 psi) with driver only; 2.5 Kg/cm² (35.5 psi) with driver and passenger.

Brake adjustment. Brakes are properly adjusted if :

- the wheel rotates freely when respective control lever or pedal are in resting position,
- the braking action starts as soon as respective controls are operated.

These conditions are achieved adjusting the cables by means of screws indicated with arrows in fig. 11.

scooterhelp.com

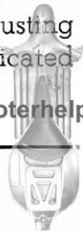

Important rules to be followed while running-in :

1. - Fuel mixture should consist of 90 cc. of oil Essolube 30 to 1 liter of gasoline, or 8% ESSO MIX.
2. - Do not exceed following speeds :
in 1st gear: 25 km/h (15.5 mph.)
» 2nd » 40 » (25 »)
» 3rd » 55 » (34 »)
» 4th » 70 » (44 »)
3. - Whenever you are forced to reduce the speed of your machine, engage the next lower gear without hesitating.

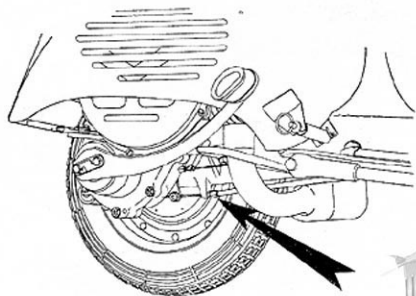
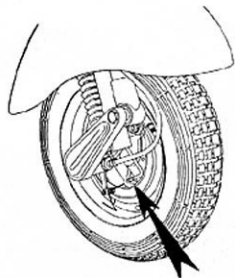

Fig. 11 - Brake adjustment



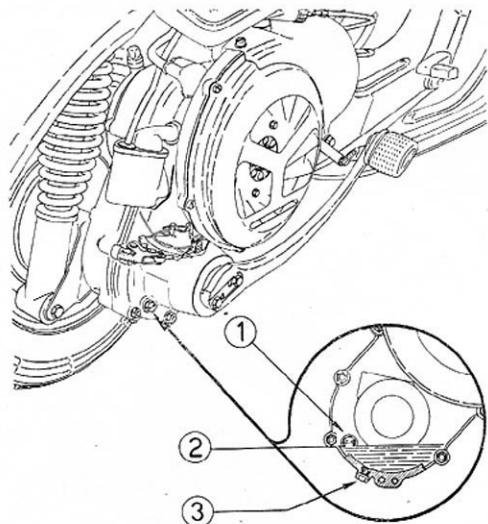

Fig. 12 - Oil level in crankcase

- 1 - Screw on filling hole 2 - Oil level
3 - Screw on draining hole

MAINTENANCE

Cleaning the scooter. Brush kerosene and wipe dry with clean rags from outside cleaning of engine.

All painted surfaces should be washed with water, deterged by means of a sponge and wiped dry with chamois leather. Do not use kerosene on such surfaces, since it damages paint and turns it dull readily.

If necessary, blow the head lamp reflector clean or wipe off dust with a very soft feather. Do not use a cloth and keep your fingers off from reflector surface.

Before setting the machine in motion check oil level in gear box by unscrew-

scooterhelp.com



ing from the crankcase the level screw marked «OLIO» (see fig. 12). The scooter standing upright, oil should just be about to flow out.

After the first 1000 Kms (600 miles). Warm up the engine and drain off all oil trough the hole provided (see fig. 12). Pour some fresh oil in and run the engine for a few seconds. Drain again and refill with new oil.

Every 2000 Kms. (1200 miles).

1) - Remove the rubber bellows connecting the air cleaner to the elbow pipe secured to the chassis, then slacken the clamp screw to release the air cleaner from the carburettor (see Fig. 13). Undo the three screws, remove the

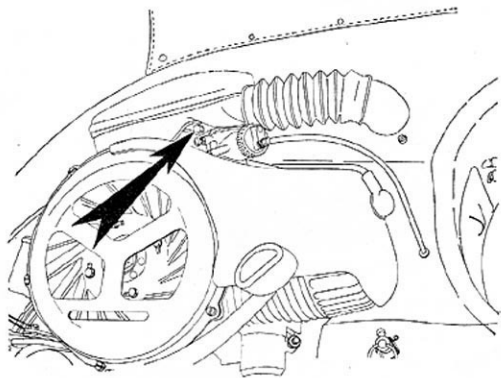
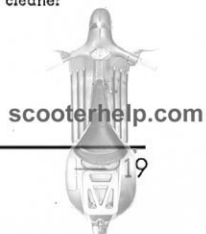

Fig. 13 - Screw securing the air cleaner



cleaner cover and wash the whole in a 30% gasoline-oil bath. Clean the elbow pipe inside and re-assemble.

2) - Check oil level in the gear box.

3) - Clean the lubricators of front wheel hub and refill them by means of a grease gun. Lubricate the speedometer drive pinion and cable.

4) - Clean the sparkplug electrodes with very fine emery cloth or suitable files, and adjust the gap to .6 mm. (.023 in.). Inspect the insulation material of sparkplug; replace the latter if the porcelain is cracked. Wash with neat gasoline.

Use the sparkplug type prescribed by the Firm. We remind to the customers that constantly using the proper type

of sparkplug will eliminate many an engine trouble.

Notice. Be careful while re-assembling the sparking plug; start screwing it by hand with proper angle, and use the box spanner just for the last turns.

N.B. - All operations indicated hereunder should be carried out by authorized Service Stations.

5) - Clean and adjust the breaker points of the flywheel magneto, (see fig. 14), to .4 mm. gap (.015 in.).

6) - Clean the silencer and decarbonize the engine.

Every 3000 Km. (1800 miles).

Grease the felt which lubricates the cam of flywheel magneto.

scooterhelp.com



In case of damper troubles, address Yourself to a service station.

Battery service : The battery is of the dry lead type, and therefore differs from the conventional batteries in that it does not contain any free acid around the plates. The electrolyte is absorbed by a special material which fills the space between the plates.

Add distilled water, **once a month**, until the level is visible and keeps unaltered, which means that the battery has absorbed the required water amount. Let the battery stand for 15 minutes then eliminate the excess water either by sucking it off with a normal densimeter or by turning the battery upsi-

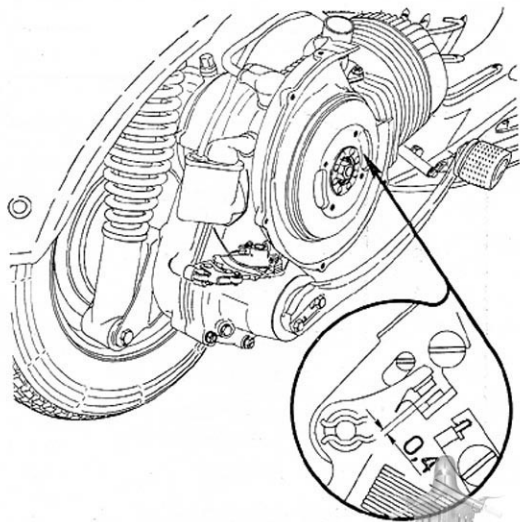

Fig. 14 - Adjustment of breaker points scooterhelp.com

LUBRICATION CHART

| Number | PARTS TO BE LUBRICATED | TIME | Page |
|--------|---------------------------------------|---|------|
| 1 | Engine (lubricated by fuel mixture) | At every refueling | 11 |
| 2 | Gear box. Complete oil change | After first 1000 Kms (600 miles) | 18 |
| | Top up | Every subsequent 2000 Kms (1200 miles) | 18 |
| 3 | Lubricators of front wheel hub | Every 2000 Kms (1200 miles) | 19 |
| 4 | Shock-absorbers | When out of order | 20 |
| | Control cables | Every 2000 Kms (1200 miles) | |
| | Felt lubricating the flywheel cam | Every 3000 Kms (1800 miles) | 20 |
| | Speedometer drive pinion and cable | Every 2000 Kms (1200 miles) | 20 |
| | Brake levers | Every 2000 Kms (1200 miles) | |
| | Gear shifter | Every 2000 Kms (1200 miles) | |

scooterhelp.com



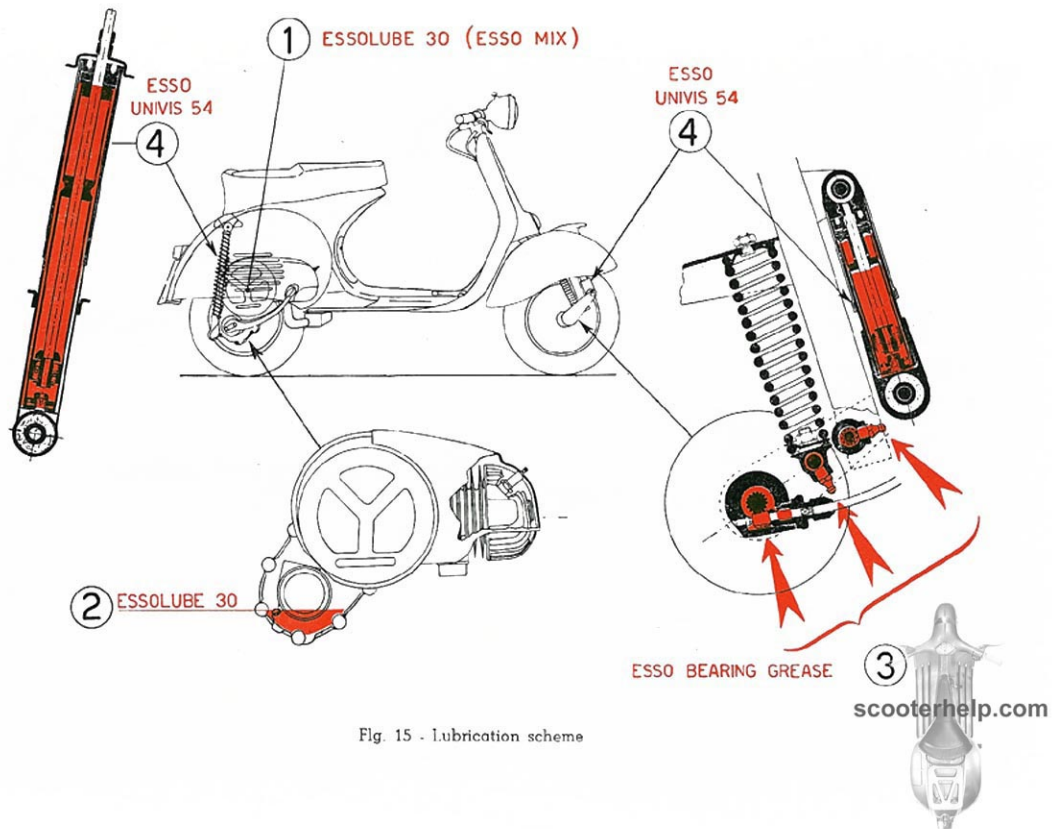

Fig. 15 - Lubrication scheme

de-down. Add distilled water after, not before a ride.

Disuse. In such a case, proceeding as follows is advisable.

1) - Clean the scooter thoroughly (see page 18).

2) Remove the air cleaner, start the engine and run it at 3/4 - full throttle in neutral. Let the engine suck in 75 cc of oil ESSOLUBE 30 through the carburettor intake.

3) - Rest the floorboard on two

wooden blocks in order to take the weight off the tyres.

4) - Drain all fuel from both tank and carburettor.

5) - Grease all unpainted metal parts.

6) - Have the battery re-charged once a month in a service station.

N. B. - Lubricate exclusively with oil and grease types as indicated on lubrication chart, page 22, and Fig. 15.



FAULT FINDING

When the machine does not run properly, make all inspections and rectifications as explained below.

If the suggested remedies are not sufficient to eliminate the trouble, the customer should not try to carry out operations pertaining to the sale agents, who have the necessary facilities to undertake this work.

| Locating the trouble | Remedies | Remarks |
|--|--|--|
| <p>HARD STARTING</p> <p>1. - Fuel system</p> <p>Fuel tank empty Fuel does not flow to the carburettor although the fuel tap is open or in position «reserve»</p> <p>Filter on sediment bowl Filter on carburettor Fuel tap body Carburettor body Main jet and atomizer Hose between fuel tap and carburettor Float needle valve sticking in its seating</p> <p style="text-align: right;">} Clogged, dirty</p> | <p>Turn to «reserve». Refill as soon as possible</p> <p>a) Unscrew the nut, under the float chamber, which clamps the intake pipe. Fuel will come out if the fuel system is efficient.</p> <p>b) Blow through jet orifice to ensure that it is clear.</p> <p>Remove and wash in gasoline - Blow dry</p> <p>Release</p> | <p>* To be carried out by a sale agent</p> |
| <p>2. - Carburetion</p> <p>Engine flooding Float perforated Air cleaner choked or dirty Choke flap sticking in position "closed,.</p> | <p>Push-start the machine</p> <p>Replace *</p> <p>See page 18, N. 1</p> <p>Release</p> | |



| Locating the trouble | Remedies | Remarks |
|---|--|--|
| <p>Float chamber assembly mounted at an angle</p> <p>3. - Ignition</p> <p>Sparking plug dirty Porcelain of sparking plug cracked Contact key not inserted Breaker points dirty, partially worn or pitted Gap between breaker points incorrect Breaker points completely worn or pitted Timing wrong</p> <p>INCORRECT RUNNING</p> <p>1. - Lack of power Silencer outlet pipe carbonised Induction pipe to cylinder loose</p> <p>Exhaust port partially closed by carbon deposit Cylinder base gasket not tight</p> <p>2. - Poor compression Sparkplug not well screwed into cylinder head Cylinder head not fitting properly into the spigot on top of cylinder Head gasket not tight Piston rings gummed up</p> | <p>Turn to vertical position</p> <p>Disconnect the plug lead. Check if sparking occurs between lead and crankcase when the kickstarter is operated. Clean. Correct gap to .6 mm. (.023"), (see page 19). Replace the plug (see «Notice», page 20). Insert. Clean with suitable files or very fine emery paper* Correct to .4 mm. with feeler gauge (.015") * Replace * Re-time ignition *</p> <p>Clean * Replace the packing between pipe and cylinder. Tighten the nuts on cylinder studs. Decarbonise cylinder, piston and cylinder head * Replace *</p> <p>Tighten with 21 mm. box spanner. Set the head properly and tighten the nuts.</p> <p>Replace Clean the rings and grooves *</p> | <p>* To be carried out by a sale agent</p> |



| Locating the trouble | Remedies | Remarks |
|---|--|---|
| <p>3. - Explosions at silencer and carburettor Sparking plug carbon coated or with excessive electrode gap. Carbon pearls on sparkplug insulation Pre-ignition Condenser screw loose Tip of contact breaker loose } Not enough mixture flowing to the carburettor</p> | <p>Replace or clean the plug and correct the gap to .6 mm. (.023 in) ** Clean Re-time the ignition * See paragraph «Hard starting» N. 1.</p> | |
| <p>4. - Clutch troubles a) Clutch snatches Convex plates wrongly assembled Gear pinions not lubricated properly b) Clutch slips Springs feeble Plates with cork-inserts worn or burnt c) Clutch does not disengage completely Excessive play on control cable Excessive convexity of steel plates</p> | <p>Turn convex face towards spring cups * Top up oil level and see that the screw on draining hole is tightened (see Fig. 12). Replace * Replace both plates and springs * Adjust * Replace *</p> | <p>* To be carried out by a sale agent ** Use suitable wire brush or emery paper</p> |
| <p>5. - Gear pinions disengage of own accord Gear change control cables out of adjustment Gear shifter loose on crankcase Spring of stirrup broken, feeble or missing Excessive play between actuating arm and gear shift flange Selector arms chamfered Dogs of gear pinions chipped or worn</p> | <p>Adjust * Tighten the screws Replace Replace * Replace the selector * Replace the pinions *</p> | |



| Locating the trouble | Remedies | Remarks |
|---|---|--|
| <p>6. - Starter assembly not engaging</p> <p>7. - High fuel consumption</p> <p>I - Fuel level too high in carburettor</p> <p>a) Float perforated</p> <p>b) Float needle valve not properly fitting into its seating</p> <p>II - Air cleaner choked or dirty</p> <p>III - Choke valve sticking in closed or partially closed position</p> <p>IV - Diametre of main jet orifice wrong or increased</p> <p>V - Retarded ignition</p> <p>VI - Poor compression</p> <p>8. Controls not operating properly</p> <p>Inner cables rusted</p> <p>Excessive play</p> <p>9. - Steering column becomes stiff</p> <p>10 - Excessive play of steering column</p> <p>11 - Poor braking</p> <p>Stroke of pedal or lever too long</p> <p>Brake linings oily or worn down</p> <p>Brake drums and linings scratched</p> | <p>Address yourself to a sale agent.</p> <p>Replace *</p> <p>Clean or replace both needle and seating *</p> <p>Clean with pure gasoline and blow dry. Dip into a 30% gasoline-oil bath</p> <p>Release and open completely</p> <p>Fit proper jet (1.00 mm.)</p> <p>Re-time *</p> <p>See No. 2 of this paragraph</p> <p>Lubricate or, if necessary, replace *</p> <p>Adjust *</p> <p>Slacken top race of top ball bearing *</p> <p>Replace bottom race of each bearing *</p> <p>Tighten top race of top bearing *</p> <p>Adjust (See Fig. 11 and page 18)</p> <p>Wash with gasoline and dry in air, or replace</p> <p>Ask the sale agent about oil leakage</p> <p>Replace</p> | <p>* To be carried out by a sale agent</p> |



| Locating the trouble | Remedies | Remarks |
|--|--|---|
| <p>12. - Inefficiency of suspension Noisiness Inefficiency Difficult rotation of wheel spindle } .</p> <p>13. - Engine noisy *</p> <p>14. - Faulty electric wiring Lead terminals loose or wrongly connected on L. T. socket, horn or switches (on head lamp and handlebars).</p> <p>Battery cables disconnected or loose</p> | <p>Re-connect properly (see Fig. 3, page 7) or replace and tighten the screws. Ask the sale Agent, if the trouble is not eliminated by this procedure.</p> <p>Reconnect and secure</p> | <p>* To be carried out by a sale agent</p> |

N.B. - Customers should take along one spare sparking plug before starting long journeys.

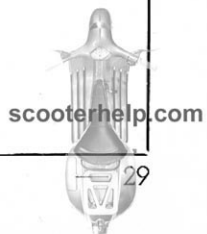

LUBRIFICAZIONE

| GRUPPO DA LUBRIFICARE | | | LUBRIFICANTI |
|--|--|--|---|
| Ogni 2000 Km. | Ogni 3000 Km. | Ogni 6000 Km. | |
| Cambio Settore cambio Articolazione levette freno Sospensione anteriore | Cavetti dei comandi Feltro del volano | Trasmissione e rin- vio contachilometri | Essolube 30 Esso Chassis Grease «L» Esso Chassis Grease «L» Esso Bearing Grease Esso Chassis Grease «L» Esso Bearing Grease Esso Bearing Grease |
| Motore: ad ogni rifornimento (lubrificazione effettuata dalla miscela) | | | Essolube 30 |
| Ammortizzatori anter. e poster. | } solo in caso di inefficienza | | Esso Univis 54 |

STABILIMENTO DI PONTEDERA

Ufficio Tecnico Commerciale

N. Dis. 24614

1 st Edition, 1500/1



scooterhelp.com

secca, ossia a differenza dei tipi correnti, non contiene acido libero nel quale sono immerse le piastre.

L'elettrolito impregna una speciale sostanza assorbente che riempie tutto lo spazio disponibile tra le piastre.

Una volta al mese aggiungere acqua distillata fino a che il livello del liquido sia visibile e resti costante; ciò indica che la batteria ha assorbito la quantità necessaria di acqua distillata. Il liquido in eccedenza, dopo aver lasciato la batteria in riposo per 15 minuti, deve essere eliminato aspirandolo con un normale densimetro o rovesciando la batteria.

È consigliabile aggiungere acqua distillata dopo e non prima di un viaggio.

Lunga inattività. Si consiglia di effettuare le seguenti operazioni:

1) - Pulizia generale della moto (vedi pag. 26).

2) - Col motore acceso ed a basso regime, immettere attraverso il diffusore del carburatore (previo smontaggio del depuratore aria), 60 cc. di olio ESSO-LUBE 30.

3) - Sollevare da terra le ruote appoggiando la pedana su due tacchetti di legno in modo che i pneumatici non tocchino terra.

4) - Vuotare del carburante il serbatoio e il carburatore.

5) - Spalmare di grasso antiruggine tutte le parti metalliche non verniciate.

6) - Distaccare i fili che fanno capo alla batteria, pulire gli attacchi ed asciugarli.

RICERCA DEI GUASTI E DELLE IRREGOLARITÀ DI FUNZIONAMENTO

Quando la moto presenti irregolarità di funzionamento, occorre eseguire i seguenti controlli e provvedere come a lato indicato.

In caso che, pur avendo attuato i provvedimenti indicati, l'inconveniente persista, consigliamo il cliente a rivolgersi alle officine delle Agenzie di vendita le quali dispongono dell'attrezzatura necessaria per l'appropriata esecuzione di qualsiasi riparazione e messa a punto.

| Ricerca e individuazione dell'inconveniente | Provvedimenti | Esecuzione |
|---|---|------------|
| <p>DIFFICOLTÀ D'AVVIAMENTO</p> <p>1 - Alimentazione</p> <p>Mancanza miscela nel serbatoio Miscela che non arriva al carburatore quando il rubinetto è in posizione di «aperto» oppure «riserva»</p> <p>Filtro sul carburatore Corpo del rubinetto Corpo del carburatore Getto Polverizzatore Tubo fra decantatore e carb.)</p> <p>ostruiti o sporchi</p> <p>Asticina del galleggiante bloccata nella sua sede</p> <p>2 - Carburazione</p> <p>Motore ingolfato</p> | <p>Inserire la riserva. Rifornimento appena possibile</p> <p>a) Svitare e togliere il getto. Dal suo alloggiamento uscirà miscela se il circuito di alimentazione è efficiente.</p> <p>b) Pulire il getto con aria compressa.</p> <p>Smontare e lavare in benzina. Asciugare con un getto di aria compressa.</p> <p>Disimpegnarla</p> <p>Vedere pag. 21</p> | |

| Ricerca e individuazione dell'inconveniente | Provvedimenti | Esecuzione |
|---|---|----------------------|
| Galleggiante forato Filtro aria otturato o sporco Carburatore montato in posizione errata | Sostituire * Vedere pag. 27, n. 1 Portare la vaschetta in posizione verticale | |
| 3 - Accensione Candela sporca Isolante della candela rotto Puntine del ruttore sporche Puntine del ruttore mal registrate Puntine del ruttore consumate o bucherellate Fasatura irregolare | Distaccare il cavo dalla candela e controllare se, azionando la leva di avviamento, scocca la scintilla fra l'estremità del cavo e la massa. Pulire e registrare la distanza (mm. 0,6) fra gli elettrodi (ved. pag. 28) Sostituire la candela (ved. pag. 28) Pulire con apposite limette o carta abrasiva * Correggere l'intervallo a mm. 0,4 * Sostituire * Correggere * | * Agenzie di vendita |
| IRREGOLARITÀ VARIE DI FUNZIONAMENTO | | |
| 1 - Scarso rendimento Marmitta incrostata Raccordo di ammissione allentato Luce di scarico ostruita da incrostazioni Guarnizione fra cilindro e carter inefficiente | Pulire (ved. pag. 28) Sostituire la guarnizione fra raccordo e cilindro Serrare i dadi sui prigionieri del cilindro. Disincrostare cilindro, testa e pistone * Sostituire * | |
| 2 - Scarsa compressione Candela non bene avvitata sulla testa del cilindro | Stringere con chiave da 21 | |

| Ricerca e individuazione dell'inconveniente | Provvedimenti | Esecuzione |
|--|--|--|
| Errato accoppiamento testa-cilindro Fasce elastiche incollate | Piazzare bene la testa sulla sommità del cilindro. Stringere fortemente ed uniformemente i dadi. Pulire le fasce e le gole sul pistone * | |
| 3 - Scoppi allo scarico e nel carburatore Candela incrostata o con elettrodi troppo distanti Formazione di perline sull'isolante Pre-accensione Vite di fermo del condensatore allentata) * Puntina del ruttore allentata) * Insufficiente afflusso di miscela al carburatore | Sostit. o pulire contr. la distanza tra gli elettr. (0,6)** Pulire Controllare l'esattezza del punto di accensione * Vedere paragrafo «Difficoltà d'avviamento» n. 1 | * Agenzie di vendita ** Usare spazzolino metallico o carta smerigliata. |
| 4 - Cattivo funzionamento frizione a) Innesto brusco Dischi bombati in acciaio male orientati Ingranaggi del cambio non sufficient. lubrif. b) Slittamento Molle scariche Dischi con tasselli di sughero logorati o bruciati c) Disinnesto incompleto Giuoco eccessivo al cavo di comando Curvatura eccessiva dei dischi bombati | Mont. con la convessità rivolta verso gli scodellini delle molle * Ristabilire il livello, e controllare l'avvitamento del tappo nel foro di scarico (ved. fig. 16) Sostituire * Sostituire i dischi e le molle * Registrare * Sostituire * | |
| 5 - Disinnesto spontaneo delle marce Cavi comando cambio male regolati | Registrare * | |

| Ricerca e individuazione dell'inconveniente | Provvedimenti | Esecuzione |
|---|---|----------------------|
| Settore comando cambio allentato sul carter Molla del settore smarrita, rotta o scarica Giuoco eccessivo oppure errato orientamento della levetta interna comando cambio Bracci della crociera smussati Risalti interni degli ingranaggi smussati | Avvitare a fondo le viti Rimpiazzare o sostituire Sostituire * Sostituire * Sostituire * | |
| 6 - Mancato innesto del gruppo messa in moto | Rivolgersi alle Agenzie di vendita | |
| 7 - Consumo elevato | | |
| I - Livello miscela troppo alto nel carburatore a) Galleggiante forato b) Scarsa tenuta dell'astina del galleggiante | Sostituire * Pulire o sostituire l'astina ed il coperchio vaschetta* | |
| II - Filtro aria otturato o sporco o anche parzializzatore aria fisso in posizione di «chiuso», o non completamente aperto | Lavare con benzina pura, asciugare con aria compressa. Immergerlo in un bagno benzina-olio al 30% Sbloccare levetta parzializzatore e lubrificarla | * Agenzie di vendita |
| III - Alterato il diam. del foro del getto massimo | Sostituirlo con getto regolamentare | |
| IV - Accensione ritardata | Mettere in fase * | |
| V - Scarsa compressione | Vedere n. 2 del presente paragrafo | |
| 8 - Difettoso funzionamento comandi | | |
| Cavetti ossidati nelle guaine Eccessivo giuoco | Lubrificare o, eventualmente, sostituire * Registrare * | |
| 9 - Indurimento sterzo | Allentare ghiera superiore cuscinetto superiore * | |
| | Sostituire le sedi inferiori dei cuscinetti * | |
| 10 - Eccessivo giuoco sterzo | Stringere la ghiera superiore cuscin. superiore * | |

| Ricerca e individuazione dell'inconveniente | Provvedimenti | Esecuzione |
|---|---|------------|
| <p>11 - Frenatura insufficiente Corsa eccessiva del pedale o leva Ceppi logorati; impregnati di olio</p> <p>Ceppi e tamburi rigati</p> <p>12 - Inefficienza sospensioni elastiche Rumorosità Inefficienza Difficoltà di rotazione asse ruota</p> <p>13 - Rumorosità del motore</p> <p>14 - Inefficienza impianto elettrico Terminali dei cavi distaccati o male allacciati</p> <p>Cavi della batteria distaccati o lenti Fusibile del raddrizzatore bruciato Errato orientamento dei fasci luminosi del proiettore.</p> | <p>Registrare (Vedere fig. 15 a pag. 25) Sostituire; lavare con benzina ed asciugare all'aria Consultare le Agenzie di vendita circa la perdita di olio. Sostituire.</p> <p>} Rivolgersi alle Agenzie di vendita</p> <p>Rivolgersi alle Agenzie di vendita</p> <p>Riallacciare correttamente (ved. fig. 8) o rimpiazzare le viti. Persistendo l'inconveniente occorre rivolgersi alle Agenzie di vendita. Attaccarli e stringerli Sostituire.</p> <p>Regolare correttamente il proiettore (pag. 16).</p> | |

