

I
I
I INHALTSVERZEICHNIS
I
I

I MOTOR KOMPLETT	SPALTE A 2	TAFEL 01
I KURBELGEHAEUSE - TRAVERSENBEFESTIGUNG	SPALTE B 2	TAFEL 02
I KURBELGEHAEUSEBEFESTIGUNGEN - MOTORDICHTUNGSSATZ	SPALTE C 2	TAFEL 03
I KURBELWELLENLAGER - KUEHLHAUBE	SPALTE D 2	TAFEL 04
I KURBELWELLE	SPALTE E 2	TAFEL 05
I ZYLINDER-KOLBEN-ZYLINDERKOPF-Z!NDKERZE	SPALTE F 2 - G 2	TAFEL 06
I KUPPLUNGSDECKEL	SPALTE A 3	TAFEL 07
I KUPPLUNG	SPALTE B 3	TAFEL 08
I KICKSTARTER	SPALTE C 3	TAFEL 09
I VORGELEGEZAHNRAD	SPALTE D 3	TAFEL 10
I SCHALTRASTE	SPALTE E 3	TAFEL 11
I SCHALTRASTENBEFESTIGUNG	SPALTE F 3	TAFEL 12
I SCHALTKREUZ - SCHALTWELLE - SCHALTZAHNRAEDER	SPALTE G 3	TAFEL 13
I MOTORSCHUTZABDECKUNG	SPALTE H 3	TAFEL 14
I LICHTMASCHINE OHNE ELEKTROSTARTER	SPALTE A 4	TAFEL 15
I LICHTMASCHINE MIT ELEKTROSTARTER	SPALTE B 4	TAFEL 16
I LUEFTERGEHAEUSEDECKEL	SPALTE C 4	TAFEL 17
I ELEKTRONIKZENTRALE - ZUENDKERZENSTECKER	SPALTE D 4	TAFEL 18
I OELPUMPE - 2-TAKTOEL	SPALTE A 5	TAFEL 19
I LUFTFILTER KOMPL. - VERGASER KOMPL. - VERGASERDICHTUNGSSATZ	SPALTE B 5	TAFEL 20
I LUFTFILTER - EINZELTEILE	SPALTE D 5	TAFEL 21
I VORLUFTFILTER	SPALTE E 5	TAFEL 22
I VERGASEREINZELTEILE - SCHWIMMER	SPALTE F 5	TAFEL 23
I VERGASEREINZELTEILE - DUESEN - GASSCHIEBER	SPALTE G 5	TAFEL 24
I ANLASSERMOTOR	SPALTE A 6	TAFEL 25
I ANLASSERMOTOR - WICKLUNG	SPALTE C 6	TAFEL 26
I HINTERRADBREMSE - BREMSTROMMEL - BREMSBACKEN	SPALTE A 7	TAFEL 27
I HINTERRADBREMSE - BREMSBACKENHALTER - BREMSZYLINDER	SPALTE B 7	TAFEL 28
I SCHALLDAEMPFER	SPALTE C 7	TAFEL 29
I RESERVERADHALTER - BORDWERKZEUG	SPALTE D 7	TAFEL 30
I FAHRGESTELL - STEUERROHRSCHUTZ	SPALTE A 8	TAFEL 31
I SPOILER - FUSSMATTEN	SPALTE B 8	TAFEL 32
I SEITENHAUBEN - NUMMERNSCHILDTRAEGER	SPALTE C 8	TAFEL 33
I GERAUESCHDAEMMATTEN - SEITENHAUBEN	SPALTE D 8	TAFEL 33/1
I GEPAECKFACH - SCHLITZROHRE	SPALTE E 8	TAFEL 34
I SITZBANK - HALTEGRIFF	SPALTE F 8	TAFEL 35
I SITZBANKBEFESTIGUNG - TASCHENHAKEN	SPALTE G 8	TAFEL 36
I OELTANK -2-TAKTOEL	SPALTE A 9	TAFEL 37
I BENZINTANK	SPALTE B 9	TAFEL 38
I KIPPSTAENDER	SPALTE C 9	TAFEL 39
I SCHLOSSZYLINDER	SPALTE A 10	TAFEL 40

I			I	
I			I	ITAFEL
I			I	I
I			I	I
I	COCKPITINSTRUMENTE	SPALTE A 16	TAFEL 59	I
I				I
I	DICHTUNGSSATZ - MOTOR	SPALTE C 2	TAFEL 03	I
I	DUESEN	SPALTE G 5	TAFEL 24	I
I				I
I	ELEKTRISCHES BENZINVENTIL	SPALTE B 5	TAFEL 20	I
I	ELEKTRONIKZENTRALE	SPALTE D 4	TAFEL 18	I
I	ELEKTRONISCHER REGLER	SPALTE D 17	TAFEL 64	I
I	ELEKTROSTARTERMOTOR	SPALTE A 6	TAFEL 25	I
I	ELEKTROSTARTERMOTORWICKLUNG	SPALTE C 6	TAFEL 26	I
I				I
I	FAHRGESTELL	SPALTE A 8	TAFEL 31	I
I	FELGEN	SPALTE A 13	TAFEL 52	I
I	FERNSCHALTER FUER ANLASSERMOTOR	SPALTE A 18	TAFEL 65	I
I	FUSSBREMSPEDAL	SPALTE B 13	TAFEL 53	I
I	FUSSMATTE	SPALTE B 8	TAFEL 32	I
I				I
I	GASDREHGRIFF	SPALTE E 10	TAFEL 44	I
I	GASSCHIEBER	SPALTE G 5	TAFEL 24	I
I	GASZUG	SPALTE A 15	TAFEL 57	I
I	GEPAECKFACH	SPALTE E 8	TAFEL 34	I
I	GEPAECKFACHSCHLOSSZYLINDER	SPALTE A 10	TAFEL 40	I
I	GEPAECKHAKEN	SPALTE G 8	TAFEL 36	I
I	GERAEUSCHDAEMMUNG - SEITENHAUBEN	SPALTE D 8	TAFEL 33/1	I
I	GLEICHRICHTER	SPALTE D 17	TAFEL 64	I
I				I
I	HALTEGRIF	SPALTE F 8	TAFEL 35	I
I	HAUPTBREMSZYLINDER	SPALTE C 13	TAFEL 53	I
I	HINTERRADBREMSBACKEN	SPALTE A 7	TAFEL 27	I
I	HINTERRADBREMSBACKENHALTER	SPALTE B 7	TAFEL 28	I
I	HINTERRADBREMSTROMMEL	SPALTE A 7	TAFEL 27	I
I	HINTERRADBREMSZYLINDER	SPALTE B 7	TAFEL 28	I
I	HINTERRADSTOSSDAEMPFER	SPALTE B 14	TAFEL 56	I
I	HUPE	SPALTE B 17	TAFEL 62	I
I	HUPENGLEICHRICHTER	SPALTE D 17	TAFEL 64	I
I				I
I				I
I				I
I				I
I				I
I				I
I				I
I				I
I				I
I				I
I				I
I				I
I				I
I				I
I				I
I				I
I				I
I				I
I				I
I				I

I
I
I

I
I
I

I
I
I
I
I

I

I

I

I

I KABELAST, BATTERIE

I KABELAST, LENKER

I KABELAST, RUECKLEUCHTE

I KABELBAUM

I KAROSSERIE

I KICKSTARTER

I KIPPSTAENDER

I KOLBEN

I KOLBENRINGE

I KOTFLUEGEL - VORDERRAD

I KUEHLHAUBE

I KUPPLUNG

I KUPPLUNGSDECKEL

I KUPPLUNGSHANDHEBEL

I KUPPLUNGSZUG

I KURBELGEHAEUSE KPL.

I KURBELGEHAEUSEBEFESTIGUNG

I KURBELWELLE

I KURBELWELLENLAGER

I

I LEERLAUFANZEIGEGERBER

I LENKER

I LENKER KPL.

I LENKERKABELAST

I LENKEROBERTEIL

I LENKERUNTERTEIL

I LENKSCHLOSSPERRWALZE

I LENKSCHLOSSZYLINDER

I LICHTMASCHINE MIT ELEKTROSTARTER

I LICHTMASCHINE OHNE ELEKTROSTARTER

I LICHTSCHALTER

I LUEFTERGEHAEUSEDECKEL

I LUFTFILTER IM FAHRGESTELL

I LUFTFILTER KPL. AM VERGASER

I LUFTFILTEREINSATZ AM VERGASER

I LUFTFILTEREINZELTEILE AM VERGASER

I LUFTFILTERGEHAEUSE AM VERGASER

I

I

I

I

I

I

I

I

I

I

I

I

I

I

I

I

I

I

SPALTE A 18

TAFEL 65

SPALTE B 16

TAFEL 60

SPALTE A 17

TAFEL 61

SPALTE B 18

TAFEL 66

SPALTE A 8

TAFEL 31

SPALTE C 3

TAFEL 09

SPALTE C 9

TAFEL 39

SPALTE F 2 - G 2

TAFEL 06

SPALTE G 2

TAFEL 06

SPALTE A 11

TAFEL 45

SPALTE D 2

TAFEL 04

SPALTE B 3

TAFEL 08

SPALTE A 3

TAFEL 07

SPALTE D 10

TAFEL 43

SPALTE A 15

TAFEL 57

SPALTE B 2

TAFEL 02

SPALTE C 2

TAFEL 03

SPALTE E 2

TAFEL 07

SPALTE D 2

TAFEL 04

SPALTE E 3

TAFEL 11

SPALTE C 10

TAFEL 42

SPALTE B 10

TAFEL 41

SPALTE B 16

TAFEL 60

SPALTE C 10

TAFEL 42

SPALTE C 10

TAFEL 42

SPALTE B 11

TAFEL 46

SPALTE A 10

TAFEL 40

SPALTE B 4

TAFEL 16

SPALTE A 4

TAFEL 15

SPALTE B 17

TAFEL 62

SPALTE C 4

TAFEL 17

SPALTE E 5

TAFEL 22

SPALTE B 5

TAFEL 20

SPALTE D 5

TAFEL 21

SPALTE D 5

TAFEL 21

SPALTE D 5

TAFEL 21

I

I

I

I

I

I

I

I

I

I

I

I

I

I

I

I

I

I

I

I

I

I

I

I

I

I

I

I

I

I

I

I

I

I

I

I

I

I

I

I

I

I

I

I

I

I

I

I

I

I

I

I

I

I

I

I

I

I

I

I

I

I			I	I
I			I	ITAFEL
I			I	I
I			I	I
I			I	I
I MOTOR KPL.	SPALTE A	2	TAFEL 01	I
I MOTORDICHTUNGSSATZ	SPALTE C	2	TAFEL 03	I
I MOTORSCHUTZABDECKUNG	SPALTE H	3	TAFEL 14	I
I				I
I NUMMERNschildTRAEGER	SPALTE C	8	TAFEL 33	I
I				I
I OELPUMPE - 2-TAKTOEL	SPALTE A	5	TAFEL 19	I
I OELSTANDSANZEIGER - 2-TAKTOEL	SPALTE A	9	TAFEL 37	I
I OELTANK - 2-TAKTOEL	SPALTE A	9	TAFEL 37	I
I				I
I PICK - UP MIT ELEKTROSTARTER	SPALTE B	4	TAFEL 16	I
I PICK - UP OHNE ELEKTROSTARTER	SPALTE A	4	TAFEL 15	I
I PLEUELLAGER	SPALTE E	2	TAFEL 05	I
I				I
I RADZIERKAPPE	SPALTE A	13	TAFEL 52	I
I RAEDER	SPALTE A	13	TAFEL 52	I
I REGLER, ELEKTRON.	SPALTE D	17	TAFEL 64	I
I REIFEN				I
I REIFEN	SPALTE A	13	TAFEL 52	I
I RESERVERADHALTER	SPALTE D	7	TAFEL 30	I
I RESERVERADSCHUTZ	SPALTE D	7	TAFEL 30	I
I ROTOR MIT ELEKTROSTARTER	SPALTE B	4	TAFEL 16	I
I ROTOR OHNE ELEKTROSTARTER	SPALTE A	4	TAFEL 15	I
I RUECKLEUCHTE	SPALTE A	17	TAFEL 61	I
I RUECKSPIEGEL	SPALTE B	10	TAFEL 41	I
I				I
I SCHALLDAEMPFER	SPALTE C	7	TAFEL 29	I
I SCHALTDREHGRIFF	SPALTE D	10	TAFEL 43	I
I SCHALTKREUZ	SPALTE G	3	TAFEL 13	I
I SCHALTRASTE	SPALTE E	3	TAFEL 11	I
I SCHALTRASTENBEFESTIGUNG	SPALTE F	3	TAFEL 12	I
I SCHALTWELLE	SPALTE G	3	TAFEL 13	I
I SCHALTZAHRaedER	SPALTE G	3	TAFEL 13	I
I SCHALTZUG	SPALTE B	15	TAFEL 58	I
I SCHEINWERFER	SPALTE A	17	TAFEL 61	I
I SCHLITZROHRE	SPALTE E	8	TAFEL 34	I
I SCHLOSSZYLINDER	SPALTE A	10	TAFEL 40	I
I SCHLUSSLEUCHTE	SPALTE A	17	TAFEL 61	I
I SCHLUSSLICHTTRAEGER	SPALTE A	8	TAFEL 31	I
I SCHWIMMER	SPALTE F	5	TAFEL 23	I
I SCHWIMMERNADEL	SPALTE F	5	TAFEL 23	I
I				I
I				I
I				I
I				I
I				I
I				I
I				I
I				I
I				I
I				I
I				I
I				I
I				I
I				I
I				I
I				I
I				I
I				I
I				I
I				I
I				I
I				I
I				I
I				I
I				I

ITAFEL 02 KURBELGEHAEUSE - TRAVERSENBEFEST. SPALTE 2B



ABB. BENENNUNG	ERSATZTEIL	ST	IKENNZIFFER	IBEMERKUNGEN
1 KURBELGEHAEUSE	I 238838	I 1	1500,510,	IA: MIT ABB. 2 - I
	I	I 1	I	I 12 DER TAFEL I
1 KURBELGEHAEUSE	I 238855	I 1	1505,515,	I 2; ABB. 3,12 I
	I	I 1	I	I DER TAFEL 2, I
1 KURBELGEHAEUSE	I 249078	I 1	1495,	I ABB. 3 - 12 I
	I	I 1	I	I DER TAFEL 9; I
2 STIFTSCHRAUBE	I S 000521	I 2	1500,505,510,	I ABB. 8 DER I
	I	I 1	1495,515,	I TAFEL 10, ABB. I
3 ZYLINDERSTEH- BOLZEN	I S 000553	I 4	1500,505,510,	I 21 DER TAFEL I
	I	I 1	1515,	I 11. I
	I	I 1	I	I I
3 ZYLINDERSTEH- BOLZEN	I 150656	I 4	1495,	I I I
	I	I 1	I	I I
4 STIFTSCHRAUBE	I 239153	I 4	1500,505,510,	I I I
	I	I 1	1515,	I I I
4 STIFTSCHRAUBE	I 239153	I 6	1495,	I I I
	I	I 1	I	I I
5 TRAVERSENGUMMI	I 238710	I 2	1500,505,510,	I I I
	I	I 1	1495,515,	I I I
6 BUCHSE	I 238677	I 1	1500,505,510,	I I I
	I	I 1	1495,515,	I I I
7 DISTANZROHR	I 238587	I 1	1500,505,510,	I I I
	I	I 1	1515,495,	I I I
8 RING	I 238594	I 1	1500,505,510,	I I I
	I	I 1	1495,515,	I I I
9 SPRENGRING	I 238595	I 1	1500,505,510,	I I I
	I	I 1	1495,515,	I I I
10 DISTANZSTUECK	I 238799	I 1	1500,505,510,	I I I
	I	I 1	1495,515,	I I I
11 DISTANZROHR	I 223604	I 1	1500,505,510,	I I I
	I	I 1	1495,515,	I I I
12 GUMMILAGER	I 157103	I 1	1500,505,510,	I I I
	I	I 1	1495,515,	I I I
	I	I 1	I	I I
	I	I 1	I	I I
	I	I 1	I	I I
	I	I 1	I	I I
	I	I 1	I	I I
	I	I 1	I	I I
	I	I 1	I	I I
	I	I 1	I	I I
	I	I 1	I	I I
	I	I 1	I	I I
	I	I 1	I	I I
	I	I 1	I	I I
	I	I 1	I	I I
	I	I 1	I	I I
	I	I 1	I	I I
	I	I 1	I	I I
	I	I 1	I	I I
	I	I 1	I	I I
	I	I 1	I	I I
	I	I 1	I	I I
	I	I 1	I	I I
	I	I 1	I	I I
	I	I 1	I	I I
	I	I 1	I	I I
	I	I 1	I	I I
	I	I 1	I	I I
	I	I 1	I	I I
	I	I 1	I	I I
	I	I 1	I	I I
	I	I 1	I	I I
	I	I 1	I	I I
	I	I 1	I	I I
	I	I 1	I	I I
	I	I 1	I	I I
	I	I 1	I	I I
	I	I 1	I	I I
	I	I 1	I	I I
	I	I 1	I	I I
	I	I 1	I	I I
	I	I 1	I	I I
	I	I 1	I	I I
	I	I 1	I	I I
	I	I 1	I	I I
	I	I 1	I	I I

I TAFEL 03 KURBELGEHAEUSEBEFEST.-MOTORDICHT. SPALTE 2C

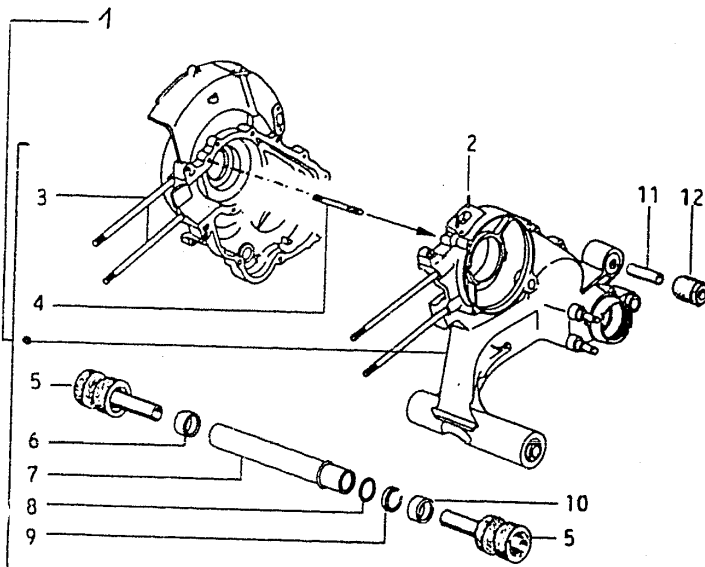
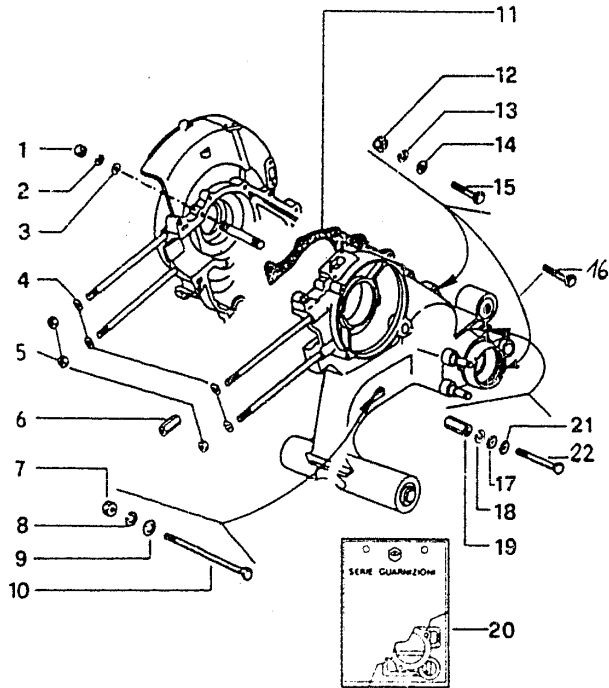

I ABB. BENENNUNG	I ERSATZTEIL	I ST	I KENNZIFFER	I BEMERKUNGEN
I 1 MUTTER	I S 020007	I 4	I 1500,505,510, 1495,515,	I
I 2 FEDERRING	I S 016407	I 4	I 1500,505,510, 1495,515,	I
I 3 FEDERRING	I S 016631	I 4	I 1500,505,510, 1495,515,	I
I 4 U.SCHEIBE	I S 013776	I 4	I 1500,505,510, 1515,	I
I 4 FEDERRING	I S 016631	I 4	I 1495,	I
I 5 MUTTER	I S 020008	I 3	I 1500,505,510, 1515,	I
I 5 MUTTER	I S 020007	I 3	I 1495,	I
I 6 BUCHSE	I 238848	I 1	I 1500,505,510, 1515,	I
I 6 BUCHSE	I 238969	I 1	I 1495,	I
I 7 MUTTER	I S 020007	I 1	I 1500,505,510, 1495,515,	I
I 8 FEDERRING	I S 016407	I 1	I 1500,505,510, 1495,515,	I
I 9 U-SCHEIBE	I S 016631	I 1	I 1500,505,510, 1495,515,	I
I 10 BOLZEN	I 239150	I 1	I 1500,505,510, 1495,515,	I
I 11 DICHTUNG	I 133184	I 1	I 1500,505,510, 1515,	I
I 11 DICHTUNG	I 133157	I 1	I 1495,	I
I 12 MUTTER	I S 020007	I 6	I 1500,505,510, 1495,515,	I
I 13 FEDERRING	I S 016407	I 6	I 1500,505,510, 1495,515,	I
I 14 U-SCHEIBE	I S 016631	I 6	I 1500,505,510, 1495,515,	I
I 15 SCHRAUBE	I 239149	I 4	I 1500,505,510, 1495,515,	I
I 16 SCHRAUBE	I 239151	I 2	I 1500,505,510, 1495,515,	I
I 17 U-SCHEIBE	I S 016631	I 1	I 1500,505,510, 1495,515,	I
I 18 FEDERRING	I S 016407	I 1	I 1500,505,510, 1495,515,	I
I 19 DISTANZBUCHSE	I 254577	I 1	I 1500,505,510, 1495,515,	I
I 20 MOTORDICHTUNGSATZI	I 154546	I 1	I 1500,505,510, 1515,	I
I 20 MOTORDICHTUNGSATZI	I 154564	I 1	I 1495,	I
I 21 U-SCHEIBE	I S 006133	I 1	I 1500,505,510, 1495,515,	I
I 22 SCHRAUBE	I 239152	I 1	I 1500,505,510, 1495,515,	I

ITAFEL 04 KURBELWELLENLAGER - KUEHLHAUBE SPALTE 2D

I ABB. BENENNUNG I ERSATZTEIL I ST IKENNZIFFER IBEMERKUNGEN I

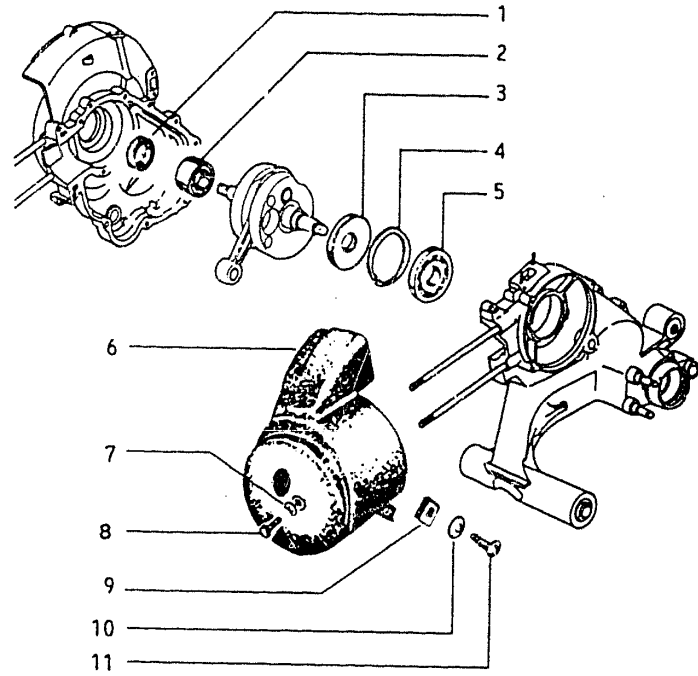

I ABB.	I BENENNUNG	I ERSATZTEIL	I ST	IKENNZIFFER	IBEMERKUNGEN
I 1	I DICHRING	I 158962	I 1	I 1500,505,510, 1495,515,	I
I 2	I KURBELWELLENLAGER I LICHTMASCH.-SEITE I	I 133068	I 1	I 1500,505,510, 1495,515,	I
I 3	I DICHRING	I 242550	I 1	I 1500,505,510, 1515,	I
I 3	I DICHRING	I 242549	I 1	I 1495,	I
I 4	I SEEGERRING	I S 006662	I 1	I 1500,505,510, 1495,515,	I
I 5	I KURBELWELLENLAGER I KUPPLUNGSSEITE I	I 97804	I 1	I 1500,505,510, 1495,515,	I
I 6	I KUEHLHAUBE	I 198450	I 1	I 1500,505,510, 1515,	I
I 6	I KUEHLHAUBE	I 239790	I 1	I 1510,515,	IA: AB FG - NR. VSR1T 0002221 I VSR1T 3001956 I
I 6	I KUEHLHAUBE	I 239594	I 1	I 1495,	I
I 7	I FEDERRING	I S 006968	I 1	I 1500,505,510, 1515,	I
I 7	I FEDERRING	I S 006977	I 1	I 1495,	I
I 8	I SCHRAUBE	I S 030283	I 1	I 1500,505,510, 1515,	I
I 8	I SCHRAUBE	I S 015522	I 1	I 1495,	I
I 9	I FEDERMUTTER	I S 008080	I 1	I 1500,505,510, 1495,515,	I
I 10	I SCHEIBE	I 97773	I 1	I 1500,505,510, 1495,515,	I
I 11	I SCHRAUBE	I S 015737	I 1	I 1500,505,510, 1495,515,	I

17

ITAFEL 05

KURBELWELLE

SPALTE 2E

I ABB. BENENNUNG I ERSATZTEIL I ST IKENNZIFFER I BEMERKUNGEN I

ITAFEL

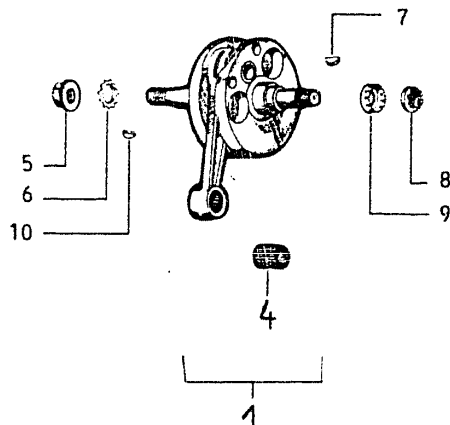

I ABB. BENENNUNG	I ERSATZTEIL	I ST	IKENNZIFFER	I BEMERKUNGEN
1 KURBELWELLE KPL.	238959	1	1500,505,510,	IA: MIT ABB. 4.
		A	1515,	
1 KURBELWELLE KPL.	241590	1	1495,	
		A	1	
4 PLEUELLAGER	93233	1	1495,	
		C	1	
4 PLEUELLAGER	151805	1	1500,505,510,	IC: IN DEN KATE-
		C	1495,515,	GORIEN 1,2,3,
5 MUTTER	S 021112	1	1500,505,510,	ODER 4 BE-
			1495,515,	STELLEN.
6 ZAHNSCHEIBE	S 012555	1	1500,505,510,	
			1495,515,	
7 KEIL	000097	1	1500,505,510,	
			1495,515,	
8 MUTTER	020375	1	1500,505,510,	
			1495,515,	
9 SICHERUNGSBLECH	022313	1	1500,505,510,	
			1495,515,	
10 KEIL	000267	1	1500,505,510,	
			1495,515,	

ITAFEL 06 ZYLINDER, -KOPF, KOLBEN, ZUENDKER SPALTE 2F

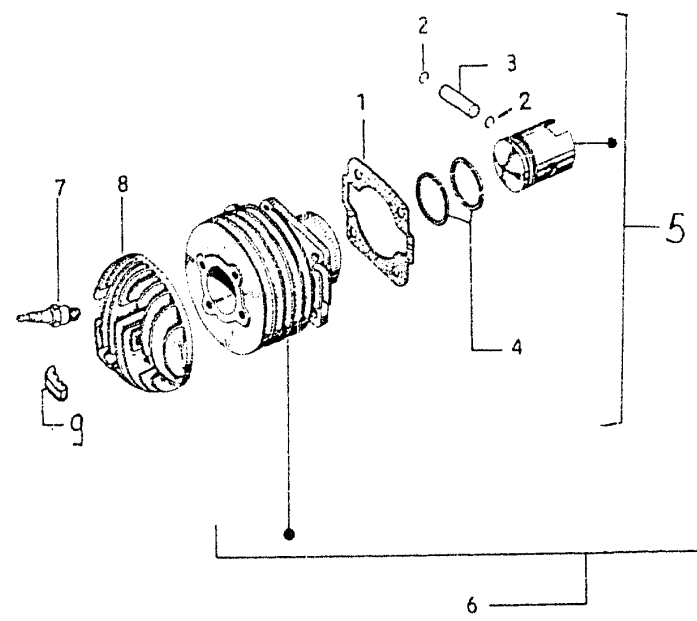

IABB. BENENNUNG	I ERSATZTEIL	I ST	IKENNZIFFER	IBEMERKUNGEN
1 FUSSDICHTUNG	1 130977	1	1500,505,510,	I
			1515,	I
1 FUSSDICHTUNG	1 191695	1	1495,	I
			I	I
2 SICHERUNGSRING	1 S 006616	1	1500,505,510,	I
			1515,	I
2 SICHERUNGSRING	1 S 006615	1	1495,	I
			I	I
3 KOLBENBOLZEN	1 119813	1	1500,505,510,	I
			1515,	I
3 KOLBENBOLZEN	1 150869	1	1495,	I
			I	I
4 KOLBENRING NORMALMASS	1 136340	1	2 1500,505,510,	I
			1515,	I
4 KOLBENRING NORMALMASS	1 238825	1	2 1495,	I
			I	I
4 KOLBENRING 1. UEBERMASS	1 132040	1	2 1500,505,510,	I
			1515,	I
4 KOLBENRING 1. UEBERMASS	1 239100	1	2 1495,	I
			I	I
4 KOLBENRING 2. UEBERMASS	1 132041	1	2 1500,505,510,	I
			1515,	I
4 KOLBENRING 2. UEBERMASS	1 239101	1	2 1495,	I
			I	I
4 KOLBENRING 3. UEBERMASS	1 132042	1	2 1500,505,510,	I
			1515,	I
4 KOLBENRING 3. UEBERMASS	1 239102	1	2 1495,	I
			I	I
5 KOLBEN KPL. NORMALMASS	1 133918	1	1 1500,505,510,	IB: IN DEN KATE-
		ABI	1515,	GORIEN 1,2,3,1
			I	ODER 4 BE-
5 KOLBEN KPL. NORMALMASS	1 414709	1	1 1510,515,	STELLEN.
		ABI	I	IE: AB FG-NR.:
		E I	I	VSR1T 00036671
5 KOLBEN KPL. NORMALMASS	1 239328	1	1 1495,	VSR1T 30080781
		ABI	I	I
5 KOLBEN KPL. 1. UEBERMASS	1 156291	1	1 1500,505,510,	I
		A I	1515,	I
5 KOLBEN KPL. 1. UEBERMASS	1 239321	1	1 1495,	I
		A I	I	I
5 KOLBEN KPL. 2. UEBERMASS	1 156292	1	1 1500,505,510,	IA: MIT ABB. 2-4.
		A I	1515,	I
5 KOLBEN KPL. 2. UEBERMASS	1 239322	1	1 1495,	I
		A I	I	I

GEN	ITAFEL 10	VORGELEGEZAHNRAD	SPALTE 3D	IABB. BENENNUNG	ERSATZTEIL	ST	IKENNZIFFER	IBEMERKUNGEN
				1 SICHERUNGSBLECH	S 016305	1	1500,505,510, 1495,515,	
				2 SEEGERRING	S 006642	1	1500,505,510, 1495,515,	
				3 LAGER	112793	1	1500,505,510, 1515,	
				3 LAGER	030209	1	1495,	
				4 VORGELEGEWELLE	174515	1	1500,505,510, 1495,515,	
				5 ROLLEN	002457	21	1500,505,510, 1495,515,	
				6 KICKSTARTERRITZEL	113526	1	1500,505,510, 1495,515,	
				7 FEDER	139100	1	1500,505,510, 1495,515,	
				8 AUFNAHMEBUCHSE	174514	1	1500,505,510, 1495,515,	
				9 NIETE	S 005765	6	1500,505,510, 1495,515,	
				10 INNERE SCHEIBE	077371	1	1500,505,510, 1495,515,	
				11 FEDER	078853	6	1500,505,510, 1495,515,	
				12 VORGELEGEZAHNRAD	236222	1	1500,505,510, 1515,	
				12 VORGELEGEZAHNRAD	137334	1	1495,	
				13 ZAHNKRANZ	174825	1	1500,505,510, 1495,515,	
				14 AUSSERE SCHEIBE	077370	1	1500,505,510, 1495,515,	
				15 VORGELEGEZAHNRAD KOMPLETT	236223	1	1500,505,510, 1515,	IA: MIT ABB. 9 - 14, 18.
				15 VORGELEGEZAHNRAD KOMPLETT	174735	1	1495,	IB: MIT ABB. 9-14
				16 FEDERRING	S 016612	1	1500,505,510, 1495,515,	
				17 MUTTER	S 015231	1	1500,505,510, 1495,515,	
				18 FEDER	077372	6	1500,505,510, 1515,	

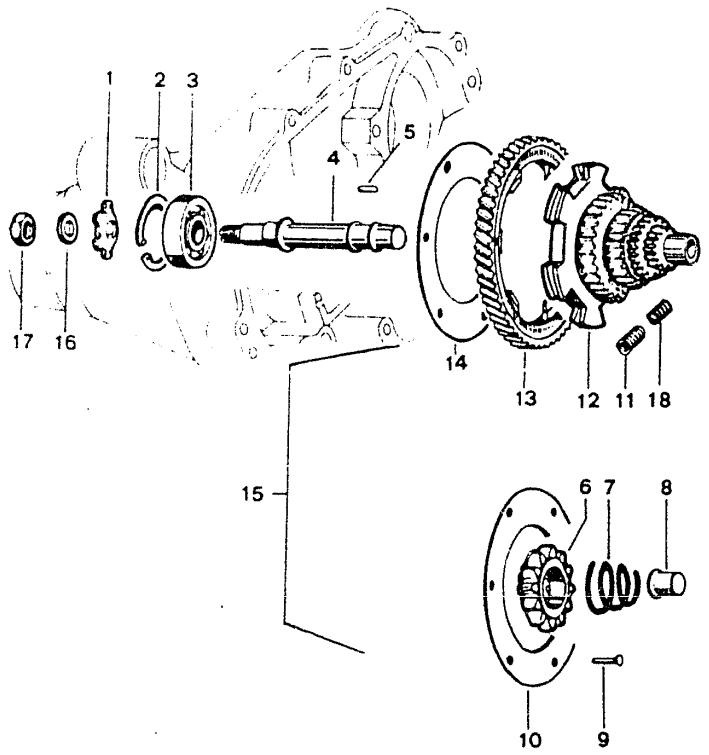

- NR.
0002221
30019561

STAB-NR.	SPALTE	ZEICHEN	TAFEL	BENENNUNG	ERSATZTEIL	STÜCK	IKENNZIFFER	BEMERKUNGEN
	3E	I	11	I	I	I	I	I
B. 4.		I		1 DECKEL	138865	1	1500,505,510,	
		I		2 BUNDBOLZEN	046612	1	1495,515,	
		I		3 SCHALTNOCKEN	046613	1	1500,505,510,	
KATE- 1,2,3, BE- N.		I		4 KEGELSTIFT	S 013010	1	1495,515,	
		I		5 SCHALTRASTE	199804	1	1500,505,510,	
		I		6 SCHRAUBE	059407	A 1	1495,515,	IA: MIT ABB. 2-4.
		I		7 HALTER	059408	1	1500,505,510,	
		I		7 HALTER	285452	1	1495,515,	IC: AB JULI 1989
		I		8 FEDER	285411	C 1	1515,495,	
		I		9 EINSTELLSCHRAUBE	090527	1	1495,515,	
		I		10 MUTTER	S 020105	2	1500,505,510,	
		I		11 SCHALTRASTGE- HAEUSE	188774	1	1495,515,	
		I		11 SCHALTRASTGE- HAEUSE	285478	C 1	1515,495,	
		I		12 SCHALTRASTE KPL.	199803	B 1	1495,515,	IB: MIT ABB. 5- 11, 14 - 17.
		I		13 SCHELLE	185365	1	1500,505,510,	
		I		15 ZAPFEN	167302	1	1495,515,	
		I		16 FEDER	188778	1	1500,505,510,	
		I		17 LEERLAUFANZEIGE- GEBER	189130	1	1495,515,	
		I		18 SCHRAUBBUCHSE	188776	1	1495,515,	

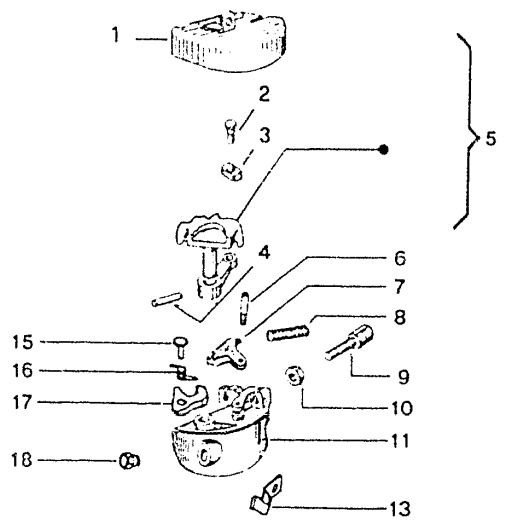

IN	ITAFEL 12	SCHALTRASTENBEFESTIGUNG	SPALTE 3F	IABB. BENENNUNG	I ERSATZTEIL	I ST	IKENNZIFFER	IBEMERKUNGEN
				1 STIFTSCHRAUBE	I 239153	I 2	1500,505,510, 1495,515,	I
				2 DICHTUNG	I 047162	I 1	1500,505,510, 1495,515,	I
				3 SCHRAUBE	I S 030280	I 1	1500,505,510, 1495,515,	I
				4 DICHTUNG	I 000397	I 1	1500,505,510, 1495,515,	I
				5 OELABLASSSCHRAUBE	I 138345	I 1	1500,505,510, 1495,515,	I
				6 DICHTUNG	I 000397	I 1	1500,505,510, 1495,515,	I
				7 MUTTER	I S 020107	I 2	1500,505,510, 1495,515,	I
				8 FEDERRING	I S 016407	I 2	1500,505,510, 1495,515,	I
				9 U-SCHEIBE	I S 003057	I 2	1500,505,510, 1495,515,	I

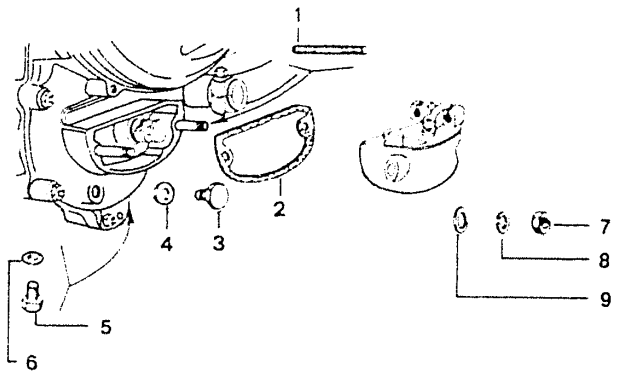

KATE-
1,2,3,
BE-
. R.:
0036671
0080781

. 2-4.1

GEN	I TAFEL 17	LUEFTERGEHAEUSEDECKEL	SPALTE 4C	I ABB. BENENNUNG	I ERSATZTEIL	I ST	I KENNZIFFER	I BEMERKUNGEN
				1 SCHRAUBE	S 015946	2	1500,505,510, 1495,515,	
				2 FEDERRING	S 016406	1	1500,505,510, 1495,515,	
				3 LUEFTERGEHAEUSE-DECKEL	179506	1	1500,505,510, 1495,515,	
				4 FEDERRING	078307	1	1500,505,510, 1495,515,	
				5 SCHRAUBE	S 015946	2	1500,505,510, 1495,515,	

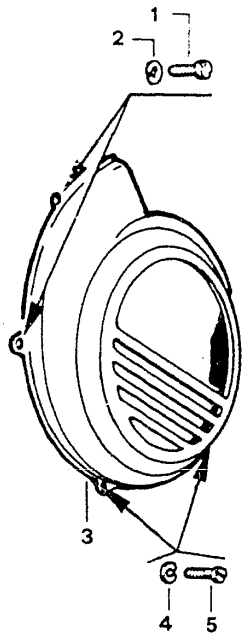

-NR:
00035511
30064731

-NR:
00040851

IB.

IN	ITAFEL 25	ANLASSERMOTOR	SPALTE 6B	IABB. BENENNUNG	ERSATZTEIL	ST	IKENNZIFFER	IBEMERKUNGEN	ITAFEL
				28 HALTER	179516	1	1505,515,		
				29 FEDERRING	S 016406	1	1505,515,		
				30 SCHRAUBE	S 031086	1	1505,515,		

1. 12, TAFEL EL 23

6-8 EL 20, 1.

EMBER

NSVER-
NG
ITON"-
G.

EMBER

IN	ITAFEL 26	ANLASSERMOTORWICKLUNG	SPALTE 6C	IABB. BENENNUNG	ERSATZTEIL	ST	IKENNZIFFER	IBEMERKUNGEN	ITAFEL
----	-----------	-----------------------	-----------	-----------------	------------	----	-------------	--------------	--------

ITAFEL 28 HINTERRADBREMSBACKENHALTER-ZYLIND SPALTE 7B

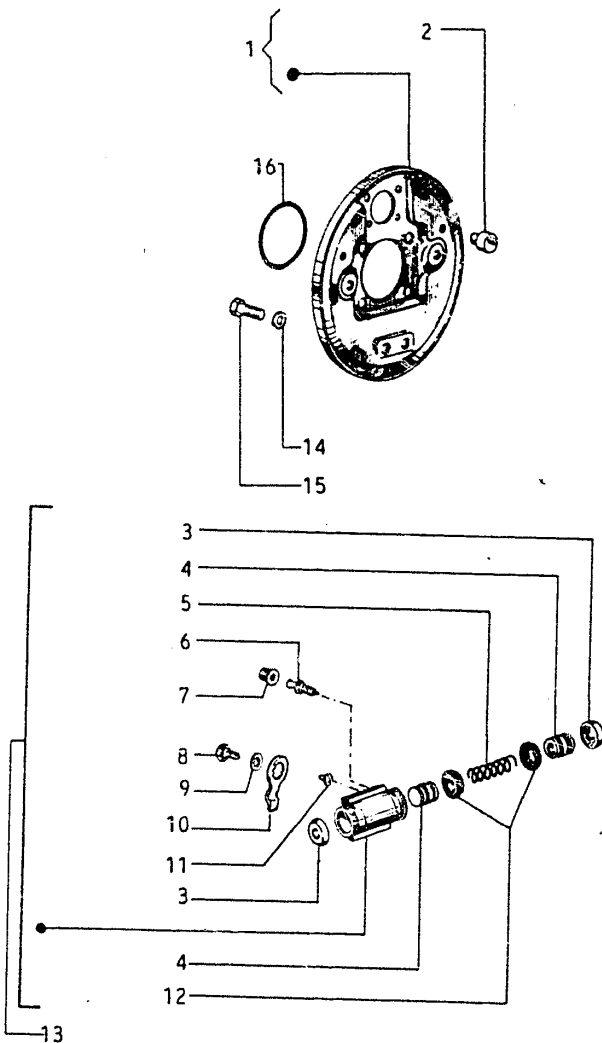

I ABB. BENENNUNG	I ERSATZTEIL	I ST	I KENNZIFFER	I BEMERKUNGEN
I 1 BREMSBACKENHALTER	I 229459	I 1	I 1500,505,510, 1495,515, IA: MIT ABB. 2.	I
I 2 NOCKEN	I 229451	I 1	I 1500,505,510, 1495,515, I	I
I 3 KAPPE	I 228833	I 2	I 1500,505,510, 1495,515, I	I
I 4 KOLBEN	I 228830	I 2	I 1500,505,510, 1495,515, I	I
I 5 FEDER	I 228832	I 1	I 1500,505,510, 1495,515, I	I
I 6 ENTLUEFTER	I 228834	I 1	I 1500,505,510, 1495,515, I	I
I 7 SCHUTZKAPPE	I 229526	I 1	I 1500,505,510, 1495,515, I	I
I 8 BOLZEN	I S 031084	I 2	I 1500,505,510, 1495,515, I	I
I 9 FEDERRING	I S 016406	I 2	I 1500,505,510, 1495,515, I	I
I 10 HALTER	I 228835	I 1	I 1500,505,510, 1495,515, I	I
I 11 VENTIL	I 229251	I 2	I 1500,505,510, 1495,515, I	I
I 12 DICHRING	I 228831	I 2	I 1500,505,510, 1495,515, I	I
I 13 BREMSZYLINDER, HINTERRAD	I 228828	I 1	I 1500,505,510, 1495,515, IB: MIT ABB. 3-7,12.	I
I 14 FEDERRING	I S 016408	I 4	I 1500,505,510, 1495,515, I	I
I 15 BOLZEN	I S 031119	I 4	I 1500,505,510, 1495,515, I	I
I 16 DICHRING	I 229536	I 1	I 1500,505,510, 1495,515, I	I
I REPARATURSATZ F. BREMSZYLINDER	I 229614	I 1	I 1500,505,510, 1495,515, I	I

ITAFEL 29	SCHALLDAEMPFER	SPALTE 7C	IABB. BENENNUNG	ERSATZTEIL	ST	IKENNZIFFER	IBEMERKUNGEN
			1 STUTZEN	130143	1	1500,505,510, 1515,	
			2 SCHELLE	140528	1	1500,505,510, 1515,	
			2 SCHELLE	130291	1	1495,	
			3 SCHALLDAEMPFER	238675	1	1500,505,510, 1515,	1A: MIT ABB. 2.
			3 SCHALLDAEMPFER	239778	1	1495,	
			4 SPRENGRING	S 016410	1	1500,505,510, 1495,515,	
			5 BOLZEN	238599	1	1500,505,510, 1495,515,	

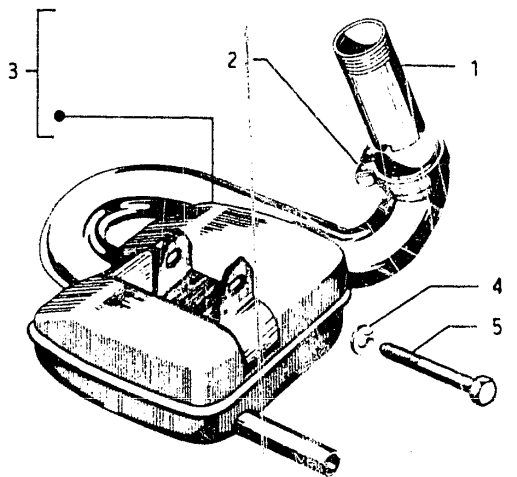

ITAFEL 30	RESERVERADHALTER-BORDWERKZEUG	SPALTE 7D	IABB. BENENNUNG	ERSATZTEIL	ST	IKENNZIFFER	IBEMERKUNGEN
-----------	-------------------------------	-----------	-----------------	------------	----	-------------	--------------

N	I	ITAFEL 31	FAHRGESTELL - STEUERROHRSCHUTZ	SPÄLTE 8A	I	I	ERSATZTEIL	ST	IKENNZIFFER	IBEMERKUNGEN	I	ITAFEL
2.	I				I	1	FAHRGESTELL	I	248456	1 1500,505,510, 1A: LACKIERTES	I	I
	I				I	1	FAHRGESTELL	I	5/256131	1495,515, I TEIL. UNBE-	I	I
	I				I	1	2 GUMMIELEMENT	I	253731	1500,505,510, I DINGT FARB-	I	I
	I				I	1	3 KUNSTSTOFFVERKLEIDUNG	I	253490	1495,515, I NUMMER ANGE-	I	I
	I				I	1	4 SCHRAUBE	I	S 018610	1500,505,510, I BEN.	I	I
	I				I	1	4 SCHRAUBE	I	S 008457	1495,515, I IC: AB FG-NR.: VNR1T 00040851	I	I
	I				I	1	5 KAPPE	I	230872	1515, I VSR1T 00035511	I	I
	I				I	1	6 SPRITZSCHUTZ	I	253975	1 I VSR1T 30064731	I	I
	I				I	1	7 GUMMIDICHTUNG	I	252126	1 1500,505,510, I BEI D. MONTA-	I	I
	I				I	1	7 GUMMIDICHTUNG	I	256290	1495,515, I GE DES NEUEN I	I	I
	I				I	1	8 SCHLUSSLICHTTRAEGER	I	253938	1515,495, I FAHRGESTELLS I	I	I
	I				I	1	9 KAPPE	I	253358	1 1500,505,510, I ANSTELLE DES I	I	I
	I				I	1	10 PFROPFEN	I	199190	1495,515, I ALTEN FAHRGE-	I	I
	I				I	1	10 PFROPFEN	I	157716	1495,515, I STELLS, MUSS I	I	I
	I				I	1	11 STEUERROHRSCHUTZ	I	251876	1 1500,505,510, I AUCH D. JE-	I	I
	I				I	1	12 SCHRAUBE	I	S 008457	1495,515, I WEILIGE HAL-	I	I
	I				I	1	13 PLAKETTE	I	252970	1 1500,505,510, I TER 256104 I	I	I
	I				I	1	14 U-SCHEIBE	I	S 003055	1495,515, I BZW. 256106 I	I	I
	I				I	1	15 DICHTGUMMI	I	253714	1 1500,505,510, I TAF. 9 UND I	I	I
	I				I	1	16 PLAKETTE	I	254594	1495,515, I DIE GUMMI-	I	I
	I				I	1	17 FEDERKLAMMER	I	S 008108	1495,515, I BUCHSE 256103I	I	I
	I				I	1		I	1495,515,	1 TAF. 58, I	I	I
	I				I	1		I	1495,515,	1 MONTIERT I	I	I
	I				I	1		I	1495,515,	1 WERDEN. I	I	I
	I				I	1		I	1495,515,	1 IB: MONTIERT AB I	I	I
	I				I	1		I	1495,515,	1 NOVEMBER 1988 I	I	I

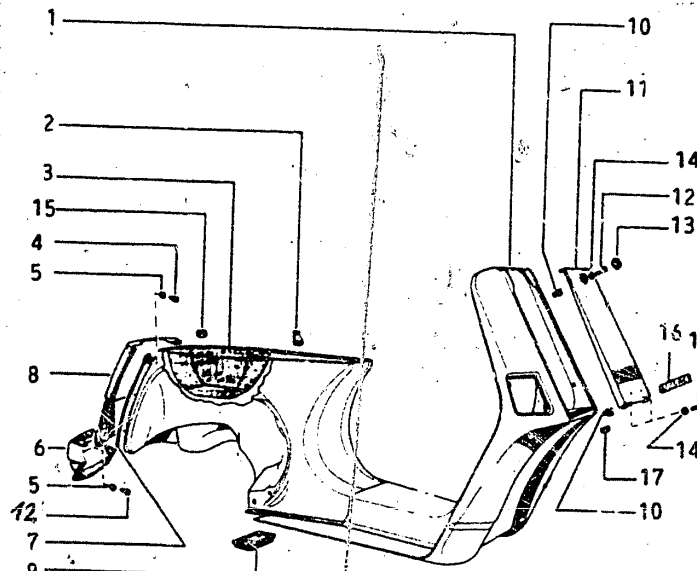

TAFEL 33 SEITENHAUBEN-NUMMERSCHILDTRAEGER SPALTE 8C

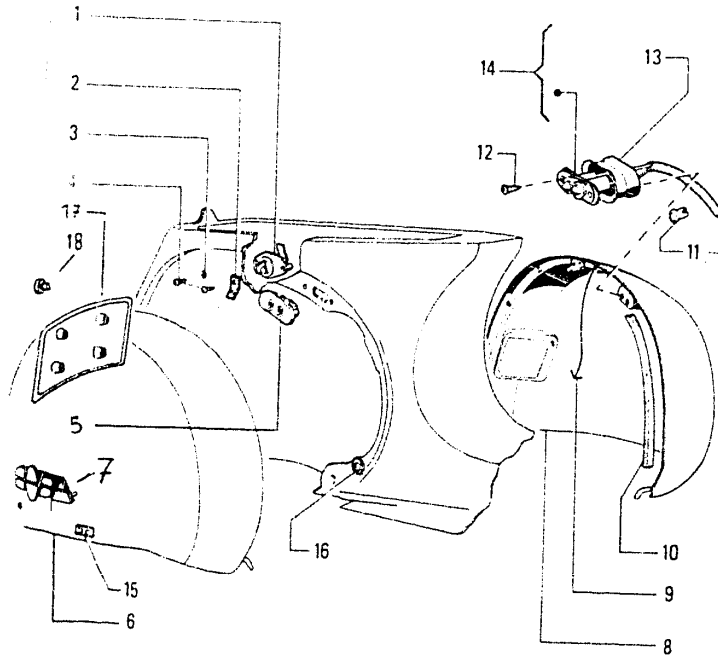

IBB. BENENNUNG	I	ERSATZTEIL	I	ST	IKENNZIFFER	IBEMERKUNGEN
1 SEITENHAUBEN-SCHLOSS, LINKS	I	254234	I	1	1500,505,510,1495,515,	I
1 SEITENHAUBEN-SCHLOSS, RECHTS	I	253266	I	1	1500,505,510,1495,515,	I
2 PLATTE	I	253643	I	2	1500,505,510,1495,515,	I
3 U-SCHEIBE	I	S 003055	I	2	1500,505,510,1495,515,	I
4 SCHRAUBE	I	S 008265	I	4	1500,505,510,1495,515,	I
5 SCHLIESSAUFNAHME	I	252379	I	2	1500,505,510,1495,515,	I
6 MOTORHAUBE, RECHTS	I	252491	B	1	1500,505,510,1495,515,	IB: LACKIERTES TEIL. UNBE- DINGT FARB- NUMMER ANGE- BEN.
7 PLAKETTE	I	254293	I	1	1500,505,510,1495,515,	I
8 RESERVERADHAUBE, LINKS	I	252490	B	1	1500,505,510,1495,515,	I
9 HALTERIEMEN	I	195556	I	2	1500,505,510,1495,515,	I
10 DICHTGUMMI	I	252797	I	2	1500,505,510,1495,515,	I
11 FEDERHALTER	I	252383	I	8	1500,505,510,1495,515,	I
12 SCHRAUBE	I	S 009000	I	4	1500,505,510,1495,515,	I
13 DICHTGUMMI	I	252378	I	1	1500,505,510,1495,515,	I
14 KONTAKTSTECKER	I	252373	I	2	1500,505,510,1495,515,	IA: MIT ABB. 13.
15 FEDERKLAMMER	I	S 008108	I	2	1500,505,510,1495,515,	I
16 PUFFER	I	253375	I	4	1500,505,510,1495,515,	I
17 NUMMERSCHILD-TRAEGER	I	253979	I	1	1500,505,510,1495,515,	I
18 SCHRAUBE	I	S 008455	I	4	1500,505,510,1495,515,	I

ITAFEL 34		GEPAECKFACH - SCHLITZROHRE	SPALTE 8E	ABB. BENENNUNG	ERSATZTEIL	ST	IKENNZIFFER	IBEMERKUNGEN
	1	SCHLITZROHR, LINKS	I	252599	I	1	1500,505,510, 1495,515,	
	2	FEDER	I	254362	I	1	1500,505,510, 1495,515,	
	3	SCHLISSHAKEN	I	252419	I	1	1500,505,510, 1495,515,	
	4	BOLZEN	I	252423	I	1	1500,505,510, 1495,515,	
	5	SCHRAUBE	I	S 008451	I	2	1500,505,510, 1495,515,	
	6	HALTER	I	252420	I	1	1500,505,510, 1495,515,	
	7	SCHEIBE	I	S 013950	I	1	1500,505,510, 1495,515,	
	8	SCHRAUBE	I	S 008375	I	1	1500,505,510, 1495,515,	
	9	SCHRAUBE	I	S 008451	I	2	1500,505,510, 1495,515,	
	10	PLAETTCHEN	I	252462	I	2	1500,505,510, 1495,515,	
	11	GEPAECKFACH	I	254539	I	1	1500,505,510, 1515,	IA: MIT ABB. 9, 10 IB: LACKIERTES
	12	PUFFER	I	252463	I	4	1500,505,510, 1495,515,	TEIL. UNBE- DINGT FARB-
	13	BUCHSE	I	252461	I	2	1500,505,510, 1495,515,	NUMMER ANGE- BEN.
	14	ABDECKUNG	I	189058	I	2	1500,505,510, 1495,515,	
	15	U-SCHEIBE	I	S 003054	I	8	1500,505,510, 1495,515,	
	16	MUTTER	I	S 020104	I	8	1500,505,510, 1495,515,	
	17	MUTTER	I	252958	I	1	1500,505,510, 1495,515,	
	18	SCHLITZROHR, RECHTS	I	252600	I	1	1500,505,510, 1495,515,	
	19	FEDERKLAMMER	I	S 008108	I	2	1500,505,510, 1495,515,	
	20	SCHILD	I	254299	I	1	1505,515,	
	20	SCHILD	I	254294	I	1	1495,	
	21	SCHILD	I	254296	I	1	1500,510,	
	22	SCHILD "GS"	I	407062	I	1	1510,515,	
	23	DICHTGUMMI FUER GEPAECKFACHDECKELI RECHTS	I	256077	I	1	1500,505,510, 1495,515,	IC: BEI MONTAGE DIE GUMMI- PUFFER ABB. 12 (4STUECK) ENTFERNEN.
	24	DICHTGUMMI FUER GEPAECKFACHDECKELI LINKS	I	256078	I	1	1500,505,510, 1495,515,	
25	DICHTGUMMI FUER GEPAECKFACHDECKELI OBEN	I	256079	I	1	1500,505,510, 1495,515,		

I TAFEL 35 SITZBANK - BEIFAHRRERHALTEGRIF I
 I SPALTE 8F

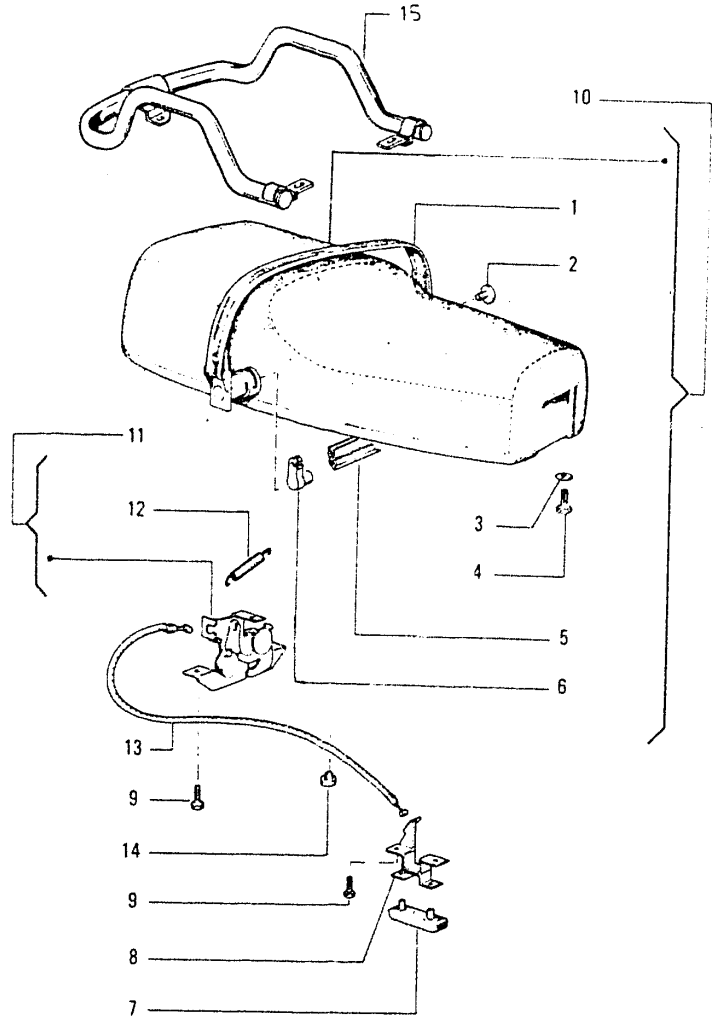

I ABB. BENENNUNG	I ERSATZTEIL	I ST	I KENNZIFFER	I BEMERKUNGEN
I 1 HALTERIEMEN	I 228598	I 1	I 1500,505,510,	I
I	I	I	I 1495,515,	I
I 1 HALTERIEMEN	I 265661	I 1	I 1500,505,510,	I IC: AB FG-NR.:
I	I	I	I 1495,515,	I VNR1T 0003980I
I 2 SCHRAUBE	I 228601	I 1	I 1500,505,510,	I VSR1T 0003457I
I	I	I	I 1495,515,	I VSR1T 3004381I
I 3 FEDERRING	I S 016406	I 4	I 1500,505,510,	I
I	I	I	I 1495,515,	I
I 4 SCHRAUBE	I S 031087	I 4	I 1500,505,510,	I
I	I	I	I 1495,515,	I
I 5 GUMMIPROFIL	I 229231	I 1	I 1500,505,510,	I
I	I	I	I 1495,515,	I
I 6 HEBEL	I 228505	I 1	I 1500,505,510,	I
I	I	I	I 1495,515,	I
I 7 PUFFER	I 228517	I 2	I 1500,505,510,	I
I	I	I	I 1495,515,	I
I 8 HALTER	I 228506	I 1	I 1500,505,510,	I
I	I	I	I 1495,515,	I
I 9 SCHRAUBE	I S 008987	I 5	I 1500,505,510,	I
I	I	I	I 1495,515,	I
I 10 SITZBANK	I 265226	I 1	I 1500,505,510,	I IA: MIT ABB. 1-14I
I	I	I	I 1495,515,	I DER TAFEL 35;I
I 10 SITZBANK	I 265226	I 1	I 1500,505,510,	I ABB. 4,5, DERI
I	I	I	I 1495,515,	I TAFEL 36.
I 11 SCHLIESSARRETIE- RUNG	I 228509	I 1	I 1500,505,510,	I
I	I	I	I 1495,515,	I
I 12 FEDER	I 228514	I 1	I 1500,505,510,	I
I	I	I	I 1495,515,	I IB: MIT ABB. 12. I
I 13 BOWDENZUG	I 228515	I 1	I 1500,505,510,	I
I	I	I	I 1495,515,	I
I 14 PUFFER	I 163778	I 2	I 1500,505,510,	I
I	I	I	I 1495,515,	I
I 15 BEIFAHRRERHALTE- GRIF	I 229644	I 1	I 1500,505,510,	I
I	I	I	I 1495,515,	I
I	I	I	I I	I
I 15 BEIFAHRRERHALTE- GRIF	I 256933	I 1	I 1500,505,510,	I ID: AB FG-NR.:
I	I	I	I 1495,515,	I VNR1T 0004359I
I	I	I	I I	I VSR1T 0003692I
I DICHUNG ZWISCHENI TASCHENHAKEN UND SITZBANK	I 265391	I 1	I 1500,505,510,	I VSR1T 3008359I
I	I	I	I 1495,515,	I
I	I	I	I I	I
I DICHUNG ZWISCHENI HALTERIEMEN UND SITZBANK LINKS	I 265392	I 1	I 1500,505,510,	I
I	I	I	I 1495,515,	I
I	I	I	I I	I
I DICHUNG ZWISCHENI HALTERIEMEN UND SITZBANK RECHTS	I 265393	I 1	I 1500,505,510,	I
I	I	I	I 1495,515,	I
I	I	I	I I	I
I	I	I	I I	I
I	I	I	I I	I
I	I	I	I I	I
I	I	I	I I	I
I	I	I	I I	I
I	I	I	I I	I
I	I	I	I I	I
I	I	I	I I	I
I	I	I	I I	I
I	I	I	I I	I
I	I	I	I I	I
I	I	I	I I	I
I	I	I	I I	I

I TAFEL 36 SITZBANKBEFESTIGUNG-TASCHENHAKEN SPALTE 8G



ABB. BENENNUNG	ERSATZTEIL	ST	IKENNZIFFER	IBEMERKUNGEN
1 BOLZEN	S 031119	2	1500,505,510, 1495,515,	
2 FEDERRING	S 016408	2	1500,505,510, 1495,515,	
3 U-SCHEIBE	S 003058	2	1500,505,510, 1495,515,	
4 SCHRAUBE	S 002451	2	1500,505,510, 1495,515,	
5 TASCHENHAKEN	253469	1	1500,505,510, 1495,515,	
6 BOLZEN	S 031119	2	1500,505,510, 1495,515,	
7 FEDERRING	S 016408	2	1500,505,510, 1495,515,	
8 U-SCHEIBE	S 003058	2	1500,505,510, 1495,515,	
9 SCHUTZKAPPE	228933	1	1500,505,510, 1495,515,	
10 HALTER	228518	1	1500,505,510, 1495,515,	

N	ITAFEL 38	BENZINTANK	SPALTÉ 9B	IABB. BENENNUNG	I ERSATZTEIL	I ST	IKENNZIFFER	IBEMERKUNGEN
				1 DECKEL	252829	1	1500,505,510, 1495,515,	
				2 BENZINANZEIGE- GEBER	252804	1	1500,505,510, 1495,515,	IA: MIT ABB. 3.
				3 DICHTUNG	252806	1	1500,505,510, 1495,515,	
				4 TANKDECKEL	252836	1	1500,505,510, 1515,	IB: MIT ABB. 5.
				4 TANKDECKEL	255100	1	1495,500,505, 1510,515,	ID: MONTIERT AB NOVEMBER 1988
				5 DICHTUNG	252803	1	1500,505,510, 1495,515,	
				6 BOLZEN	S 031119	4	1500,505,510, 1495,515,	
				7 FEDERRING	S 016408	4	1500,505,510, 1495,515,	
				7 FEDERRING	256512	2	1500,505,510, 1495,515,	IG: AB FG-NR.: VNR1T 0004359I
				8 U-SCHEIBE	S 003058	4	1500,505,510, 1495,515,	VSR1T 0003692I
				8 U-SCHEIBE	256513	2	1500,505,510, 1515,495,	VSR1T 3008359I
				9 ENTLUEFTER- SCHLAUCH	252832	1	1500,505,510, 1495,515,	
				10 BENZINTANK	252795	1	1500,505,510, 1515,	
				10 BENZINTANK	255098	1	1495,500,505, 1510,515,	IE: TANKDECKEL NR. 255100
				10 BENZINTANK	256509	1	1500,505,510, 1515,495,	IMONTIEREN.
				11 SCHELLE	197574	1	1500,505,510, 1495,515,	
				11 SCHELLE	256074	1	1500,505,510, 1495,515,	IF: AB SEPTEMBER 1989
				12 DICHTUNG	196868	1	1500,505,510, 1495,515,	
				13 ANSCHLUSSTUTZEN	252830	1	1500,505,510, 1495,515,	IC: MIT ABB. 12.
				14 BENZINSCHLAUCH	146504	1	1500,505,510, 1495,515,	IH: BEI DER MONTAGE DES BENZINTANKS 256509 AN DER STELLE DES BENZINTANKS 255098 MUESSEN IMMER 12 FEDERRINGE 1256512, 12 U-SCHEIBEN 1256513 UND 12 U-SCHEIBEN 1S 16627 MONTIERT WERDEN.
				15 FEDER	097248	1	1500,505,510, 1495,515,	
				16 SCHLAUCHDURCH- GANG	084262	1	1500,505,510, 1495,515,	
				U-SCHEIBE FUER BENZINTANK	S 16627	2	1500,505,510, 1495,515,	

R:
003551I
006473I
004085I

FES
VBE-
VRB-
VNGE-

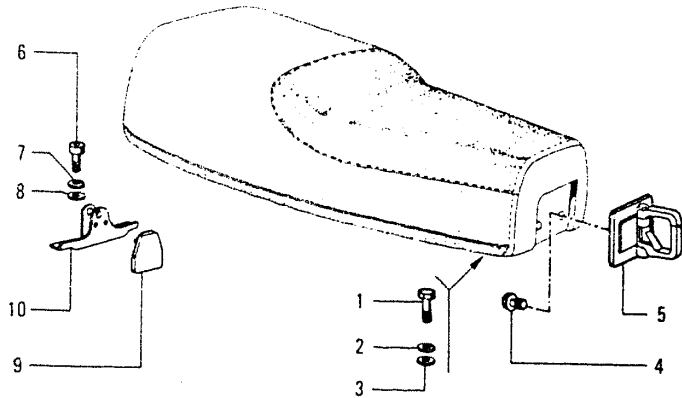
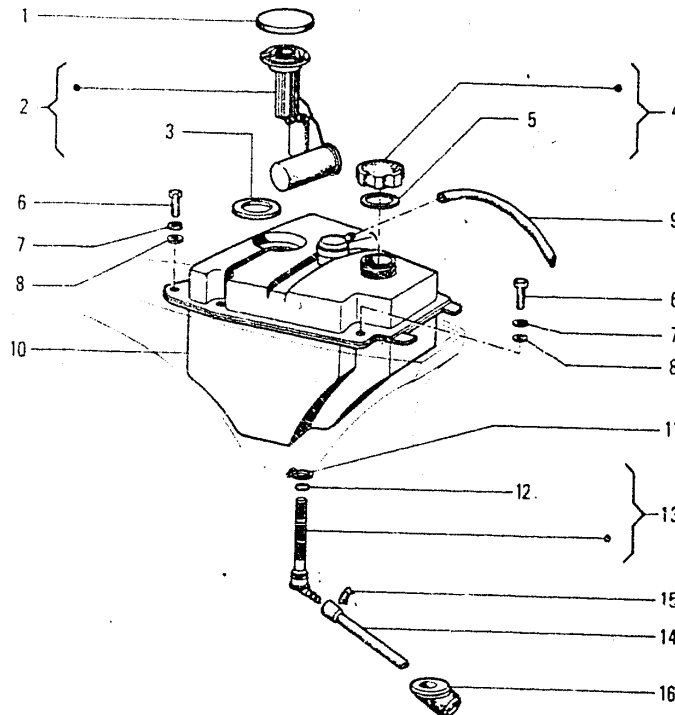

		ITAFEL 41	LENKER KOMPL. - SPIEGEL	SPALTE 10B	ITAFEL			
		I ABB. BENENNUNG I ERSATZTEIL I ST IKENNZIFFER I BEMERKUNGEN I			ITAFEL			
				1 RUECKSPIEGEL LINKS	228611	1 1500,505,510, 1515,	IE: MIT ABB. 3-9, 13.	
3.				1 RUECKSPIEGEL RECHTS	228612	1 1500,505,510, 1515,	IA: LACKIERTES TEIL. UNBEBEN.	
				1 RUECKSPIEGEL LINKS	253721	1 1500,505,510, 1515,495,		
5.				1 RUECKSPIEGEL RECHTS	229795	1 1500,505,510, 1515,495,	ID: MIT EINSTELL-SCHRAUBE.	
AB				2 ABDECKUNG	229482	2 1500,505,510, 1495,515,		
19881				3 SCHRAUBE	229483	2 1500,505,510, 1495,515,		
				4 SCHEIBE	S 003038	2 1500,505,510, 1495,515,		
				5 FEDER	229465	2 1500,505,510, 1495,515,		
043591				6 SCHEIBE	S 013869	2 1500,505,510, 1495,515,		
036921				7 KONUS	229497	2 1500,505,510, 1495,515,		
083591				8 SCHRAUBE	229498	2 1500,505,510, 1495,515,		
				9 GUMMIDECKEL, LINKS	228614	1 1500,505,510, 1495,515,		
				9 GUMMIDECKEL, RECHTS	228615	1 1500,505,510, 1495,515,		
				10 GEWINDERING	226156	2 1500,505,510, 1495,515,		
				11 NASENSCHEIBE	229570	1 1500,505,510, 1495,515,		
				12 LENKER KOMPL.	228572	1 1500,505,510, 1495,515,	IB: MIT TAFELN 42,43,44.	
				13 SPIEGELGLAS	229554	2 1500,505,510, 1515,	IC: DIE SPIEGEL-HAEFTEN MIT LOCTIT SUPER RAPIDO ABI-PLASTIC NR. 415 VERKLEBENI	
				13 SPIEGELABDECKUNG SCHWARZ M. GLAS LINKS	265373	1 1500,505,510, 1515,495,		
				13 SPIEGELABDECKUNG SCHWARZ MIT GLAS RECHTS	265454	1 1500,505,510, 1515,495,		

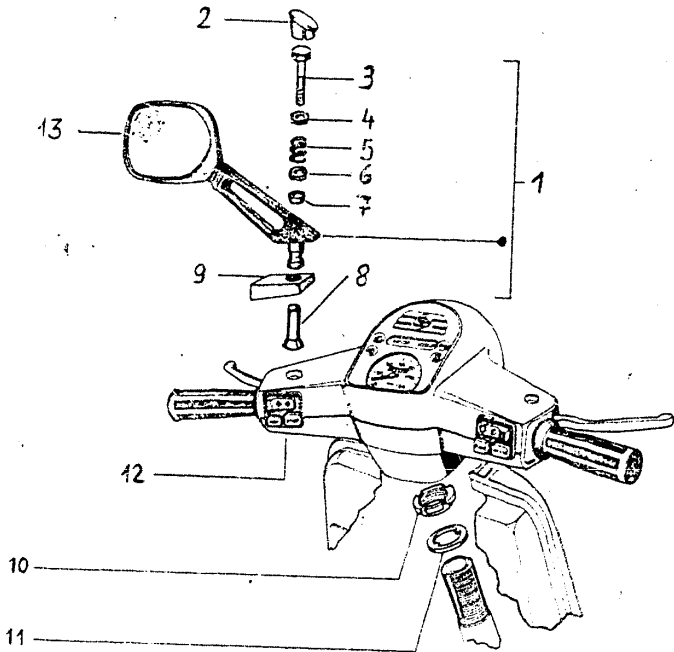

TAFEL 43		SCHALTDREHGRIFF		SPALTE 10D		IABB. BENENNUNG		I ERSATZTEIL I ST IKENNZIFFER		IBEMERKUNGEN	
I	I	I	I	I	I	I	I	I	I	I	I
I	I	I	I	I	I	I	I	I	I	I	I
I	I	I	I	I	I	I	I	I	I	I	I
I	I	I	I	I	I	I	I	I	I	I	I
I	I	I	I	I	I	I	I	I	I	I	I
I	I	I	I	I	I	I	I	I	I	I	I
I	I	I	I	I	I	I	I	I	I	I	I
I	I	I	I	I	I	I	I	I	I	I	I
I	I	I	I	I	I	I	I	I	I	I	I
I	I	I	I	I	I	I	I	I	I	I	I
I	I	I	I	I	I	I	I	I	I	I	I
I	I	I	I	I	I	I	I	I	I	I	I
I	I	I	I	I	I	I	I	I	I	I	I
I	I	I	I	I	I	I	I	I	I	I	I
I	I	I	I	I	I	I	I	I	I	I	I
I	I	I	I	I	I	I	I	I	I	I	I
I	I	I	I	I	I	I	I	I	I	I	I
I	I	I	I	I	I	I	I	I	I	I	I
I	I	I	I	I	I	I	I	I	I	I	I
I	I	I	I	I	I	I	I	I	I	I	I
I	I	I	I	I	I	I	I	I	I	I	I
I	I	I	I	I	I	I	I	I	I	I	I
I	I	I	I	I	I	I	I	I	I	I	I
I	I	I	I	I	I	I	I	I	I	I	I
I	I	I	I	I	I	I	I	I	I	I	I
I	I	I	I	I	I	I	I	I	I	I	I
I	I	I	I	I	I	I	I	I	I	I	I
I	I	I	I	I	I	I	I	I	I	I	I
I	I	I	I	I	I	I	I	I	I	I	I
I	I	I	I	I	I	I	I	I	I	I	I
I	I	I	I	I	I	I	I	I	I	I	I
I	I	I	I	I	I	I	I	I	I	I	I
I	I	I	I	I	I	I	I	I	I	I	I
I	I	I	I	I	I	I	I	I	I	I	I
I	I	I	I	I	I	I	I	I	I	I	I
I	I	I	I	I	I	I	I	I	I	I	I
I	I	I	I	I	I	I	I	I	I	I	I
I	I	I	I	I	I	I	I	I	I	I	I
I	I	I	I	I	I	I	I	I	I	I	I
I	I	I	I	I	I	I	I	I	I	I	I
I	I	I	I	I	I	I	I	I	I	I	I
I	I	I	I	I	I	I	I	I	I	I	I
I	I	I	I	I	I	I	I	I	I	I	I
I	I	I	I	I	I	I	I	I	I	I	I
I	I	I	I	I	I	I	I	I	I	I	I
I	I	I	I	I	I	I	I	I	I	I	I
I	I	I	I	I	I	I	I	I	I	I	I
I	I	I	I	I	I	I	I	I	I	I	I
I	I	I	I	I	I	I	I	I	I	I	I
I	I	I	I	I	I	I	I	I	I	I	I
I	I	I	I	I	I	I	I	I	I	I	I
I	I	I	I	I	I	I	I	I	I	I	I
I	I	I	I	I	I	I	I	I	I	I	I
I	I	I	I	I	I	I	I	I	I	I	I
I	I	I	I	I	I	I	I	I	I	I	I
I	I	I	I	I	I	I	I	I	I	I	I

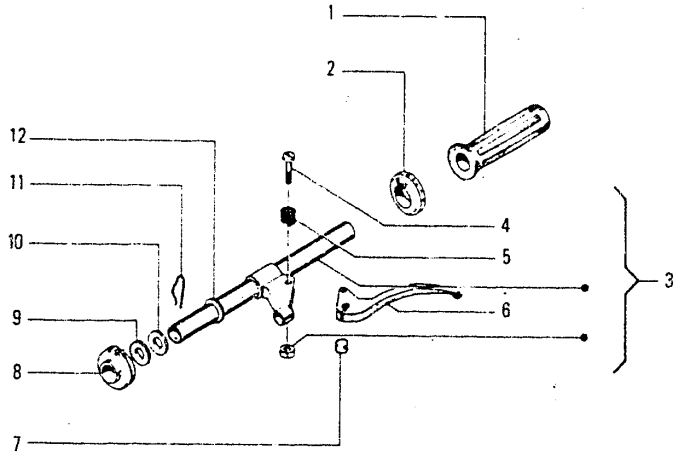

ITAFEL 44		GASDREHGRIFF	SPALTE 10E	IABB. BENENNUNG	I ERSATZTEIL	I ST	IKENNZIFFER	IBEMERKUNGEN
				1 FEDER	177072	1	1500,505,510, 1495,515,	
				1 FEDER	265792	1	1500,505,510, 1495,515,	IB: FUER BREMS-
				1 FEDER	265606	1	1500,505,510, 1495,515,	HEBEL 228536
				2 FEDER	101481	1	1500,505,510, 1495,515,	MONTIEREN.
				3 GUMMIGRIFF	228541	1	1500,505,510, 1495,515,	IC: AB JULI 1989
				4 GASDREHGRIFF	228531	1	1500,505,510, 1495,515,	M. BREMSHEBELI
				5 BREMSHEBEL	228536	1	1500,505,510, 1495,515,	265303 MON-
				5 BREMSHEBEL	265303	1	1500,505,510, 1495,515,	TIEREN.
				6 BREMSHEBEL KPL.	229173	1	1500,505,510, 1495,515,	ID: AB JULI 1989
				7 EINSTELLSCHRAUBE	154791	1	1500,505,510, 1495,515,	MIT FEDER
				8 KURZSCHLUSSKNOPF FUER FERNSCHALTERI	232204	1	1500,505,510, 1495,515,	265606 MON-
				9 FUEHRUNGSROLLE	228538	1	1500,505,510, 1495,515,	TIEREN.
				10 U-SCHEIBE	177147	1	1500,505,510, 1495,515,	IA: MIT ABB. 1,5, 7,8,12.
				11 FEDERRING	177148	1	1500,505,510, 1495,515,	
				12 SCHRAUBE UND MUTTER	265249	1	1500,505,510, 1495,515,	
				13 NIPPEL	241874	1	1500,505,510, 1515,495,	

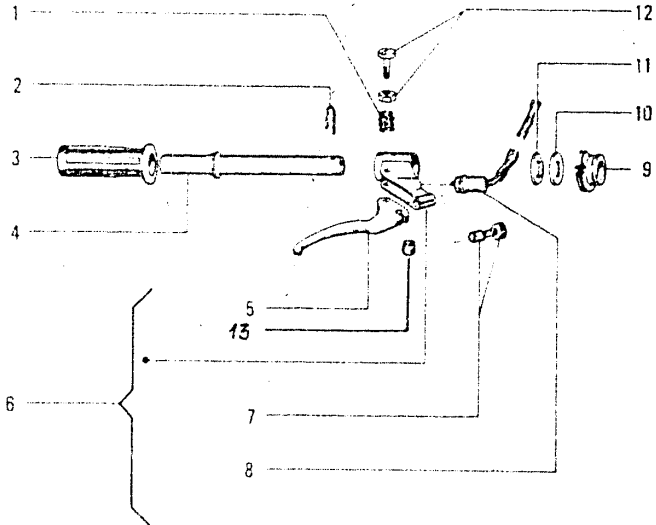

N I
TEL- I
MER I
SELNR. I
CHLUESI I
DER I
CHLUESI I

ITAFEL 45 VORDERRADKOTFLUEGEL

SPALTE 11A

IABB. BENENNUNG I ERSATZTEIL I ST IKENNZIFFER IBEMERKUNGEN I

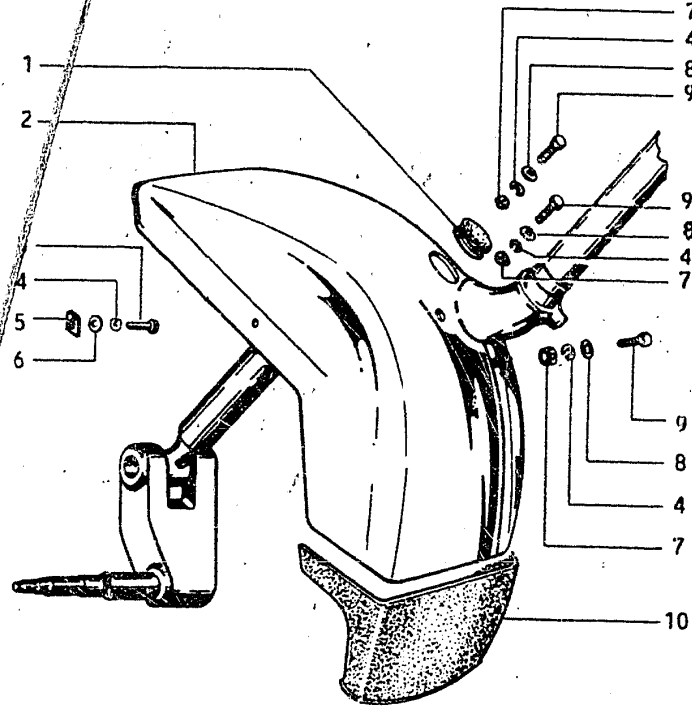

IABB. BENENNUNG	I ERSATZTEIL	I ST	IKENNZIFFER	IBEMERKUNGEN
1 PPROPfen	I 251874	I 1	1500,505,510,	I
2 KOTFLUEGEL	I 229723	I 1	1495,515,	I
3 SCHRAUBE	I S 031086	I 1	1500,505,510,	IA: LACKIERTES
4 FEDERRING	I S 016406	I 4	1495,515,	TEIL. UNBE-
5 MUTTER	I 251875	I 1	1500,505,510,	DINGT FARB-
6 U-SCHEIBE	I S 003056	I 1	1495,515,	NUMMER ANGE-
7 MUTTER	I S 020106	I 3	1500,505,510,	BEN.
8 U-SCHEIBE	I S 013880	I 3	1495,515,	
9 BOLZEN	I S 031092	I 3	1500,505,510,	
10 SPRITZSCHUTZ	I 251873	I 1	1495,515,	

8
7
9
10

ITAFEL 46		STEUERROHRLAGER-LENKSCHLOSSWALZE	SPALTE 11B	IABB. BENENNUNG	I ERSATZTEIL	I ST	IKENNZIFFER	IBEMERKUNGEN	I	I
3-9,	I			1 GEWINDERING	I	1	1500,505,510,	I	I	I
ES	I			2 NASENSCHEIBE	I	1	1495,515,	I	I	I
BE-	I			3 GEWINDERING	I	1	1500,505,510,	I	I	I
RB-	I			4 KUGELKRANZ OBEN	I	1	1495,515,	I	I	I
NGE-	I			5 LAGERSCHALE OBEN	I	1	1500,505,510,	I	I	I
	I			6 LAGERSCHALE	I	1	1495,515,	I	I	I
TELL-	I			7 KUGELLAGER UNTEN	I	1	1500,505,510,	I	I	I
	I			8 LAGERSCHALE UNTEN	I	1	1495,515,	I	I	I
	I			9 LAGERSCHALE UNTEN	I	1	1500,505,510,	I	I	I
	I			10 SPERRWALZENAUF-	I	1	1495,515,	I	I	I
	I			NAHME	I	1	1500,505,510,	I	I	I
	I			11 SPERRWALZE	I	1	1495,515,	I	I	I
	I			12 SCHLOSSAUF-	I	1	1500,505,510,	I	I	I
	I			NAHME	I	1	1495,515,	I	I	I
	I			13 STEUERLAGERSATZ	I	1	1500,505,510,	IA: MIT ABB. 1-5.	I	I
	I			OBEN	I	A	1495,515,	I	I	I
	I			14 STEUERLAGERSATZ	I	1	1500,505,510,	IB: MIT ABB. 6-9.	I	I
	I			UNTEN	I	B	1495,515,	I	I	I
	I			STEUERROHRLAGER-	I	1	1500,505,510,	IC: AB FG-NR.:	I	I
	I			ABDECKUNG	I	C	1495,515,	I	I	I
	I				I			VNR1T 00043591	I	I
	I				I			VSR1T 00036921	I	I
	I				I			VSR1T 30083591	I	I

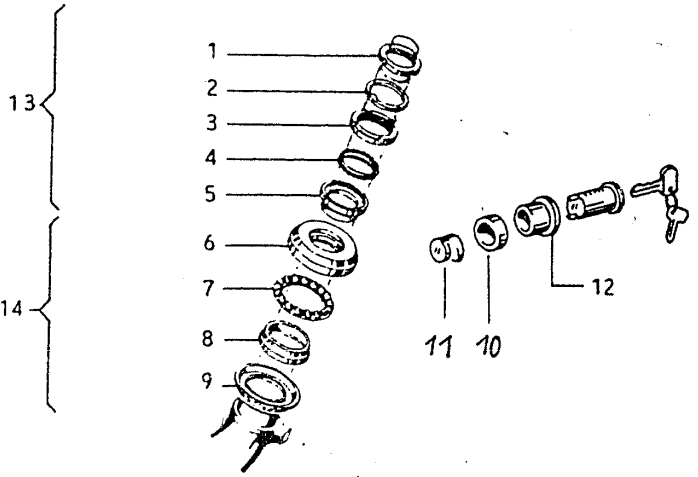

IGEN	ITAFEL 47	STEUERROHR	SPALTE 11C	IABB. BENENNUNG	I ERSATZTEIL	I ST IKENNZIFFER	IBEMERKUNGEN	ITAFEL
ERTES				1 STEUERROHR KPL.	229733	1 1500,505,510,	IA: MIT ABB. 2-6.	
UNBE-				2 NADELLAGER	198513	2 1500,505,510,		
FARB-				3 DICHRING	119219	2 1500,505,510,		
R ANGE-				4 DICHTUNG	S 006731	2 1500,505,510,		
				5 VORDERRADSCHWINGE	178051	1 1500,505,510,		
				6 ZAPFEN	177451	1 1500,505,510,		
				7 DISTANZSCHEIBE	177445	1 1500,505,510,		
				8 RING	177408	1 1500,505,510,		
				9 DECKEL	228637	1 1500,505,510,		
				10 DICHTUNG	177521	1 1500,505,510,		

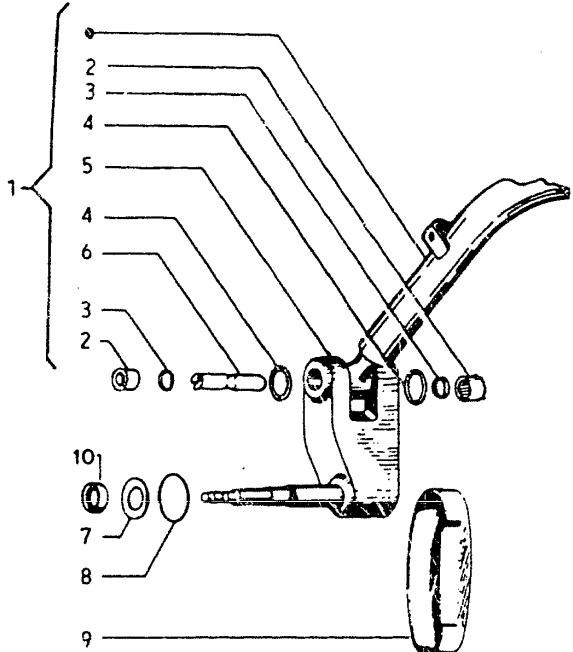

B12

IN	ITAFEL 50	VORDERRADBREMSTROMMEL	SALTE 12C	IABB. BENENNUNG	I ERSATZTEIL I	ST IKENNZIFFER	IBEMERKUNGEN	I	ITAFEL
				1 FEDERRING	I S 016408	I 5 1500,505,510,	I		
				2 MUTTER	I S 020108	I 5 1500,505,510,	I		
				3 SICHERUNGSRING	I S 006635	I 1 1500,505,510,	I		
				4 LAGER	I 177610	I 1 1500,505,510,	I		
				5 STIFTSCHRAUBE	I 085914	I 5 1500,505,510,	I		
				6 ROLLENLAGER	I 177442	I 1 1500,505,510,	I		
				7 DICHTRING	I 177443	I 1 1500,505,510,	I		
				8 DISTANZSCHEIBE	I 177414	I 1 1500,505,510,	I		
				9 SICHERUNGSRING	I S 006422	I 1 1500,505,510,	I		
				10 BREMSTROMMEL, VORDERRAD	I 228889	I 1 1500,505,510,	IA: MIT ABB. 3-7.		
				11 MUTTER	I S 021114	I 1 1500,505,510,	I		
				12 SICHERUNGSKAPPE	I 177609	I 1 1500,505,510,	I		
				13 SPLINT	I S 012787	I 1 1500,505,510,	I		
				14 KAPPE	I 197983	I 1 1500,505,510,	I		
				15 PFROPFEN	I 228820	I 1 1500,505,510,	I		

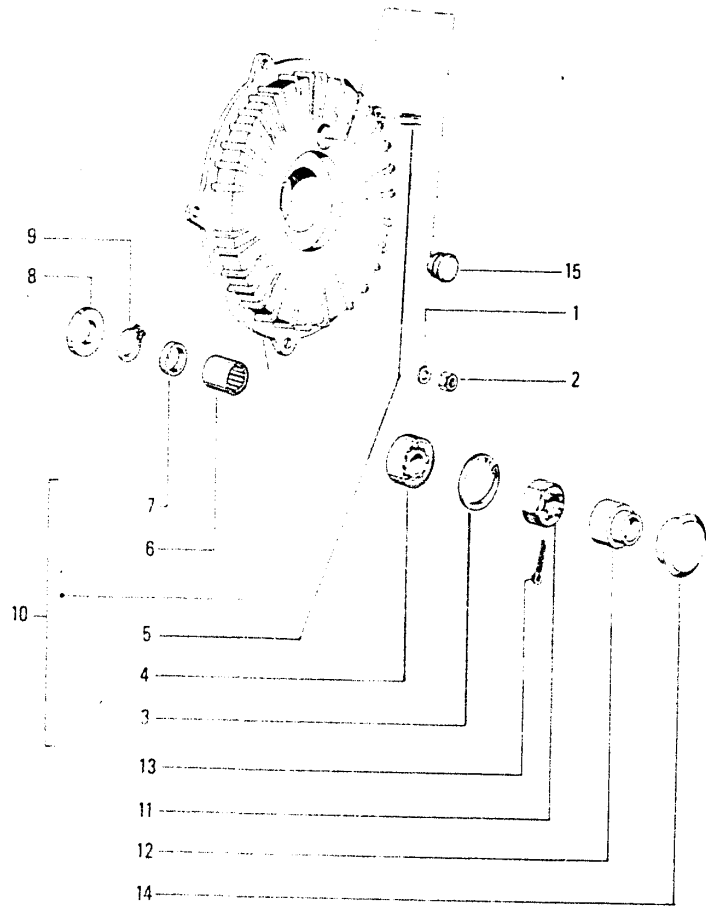

C12

EN	I	I	I	I	I	I	I	I	I	I	I	
	ITAFEL 53	BREMSPED.-HAUPTBREMSZYL.-DRUCKREG	SPALTE 13B	I	I	I	I	I	I	I	ITAFEL	
				I	ABB. BENENNUNG	I	ERSATZTEIL	I	ST	IKENNZIFFER	IBEMERKUNGEN	I
					1 SCHEIBE	I	S 013777	I	6	1500,505,510, 1495,515,	I	I
					2 STUTZEN F. HAUPTBREMSZYLINDER "BENDIX"	I	229522	I	1	1500,505,510, 1495,515,	IA: WAHLWEISE MONTIERT.	I
					2 STUTZEN F. HAUPTBREMSZYLINDER "TECNO DELTA"	I	229506	I	1	1500,505,510, 1495,515,	I	I
					3 BREMSDRUCKREGLER	I	228857	I	1	1500,505,510, 1495,515,	I	I
					4 FEDERRING	I	S 016408	I	1	1500,505,510, 1495,515,	I	I
					5 MUTTER	I	S 020108	I	1	1500,505,510, 1495,515,	I	I
					6 BEFESTIG.-PLATTE	I	228781	I	1	1500,505,510, 1495,515,	I	I
					6 BEFEST.-PLATTE	I	265299	I	1	1500,505,510, 1495,515,	IC: AB FG-NR.: VNR1T 0003131I VSR1T 0003496I VSR1T 3004434I	I
					7 BUCHSE	I	228785	I	1	1500,505,510, 1495,515,	I	I
					8 BREMSLICHTSCHALTER	I	252727	I	1	1500,505,510, 1515,	I	I
					8 BREMSLICHTSCHALTER	I	214772	I	1	1500,505,510, 1495,515,	IB: MONTIERT AB JUNI 88. BEI MONTAGE ANSTELLE DES ALTEN BREMSLICHTSCHALTERS ODER HALTERS ALLE ABB. 8,9,29 UND 30 MONTIEREN.	I
					9 HALTER	I	229261	I	1	1500,505,510, 1515,	I	I
					9 HALTER	I	254749	I	1	1500,505,510, 1495,515,	I	I
					10 FEDER	I	229275	I	1	1500,505,510, 1495,515,	I	I
					10 FEDER	I	265380	I	1	1500,505,510, 1495,515,	I	I
					11 SPLINT	I	S 003208	I	1	1500,505,510, 1495,515,	I	I
					12 ZAPFEN	I	228807	I	1	1500,505,510, 1495,515,	I	I
					13 PEDALACHSE	I	228786	I	1	1500,505,510, 1495,515,	I	I
					13 PEDALACHSE	I	265233	I	1	1500,505,510, 1495,515,	I	I
					14 BUCHSE	I	228785	I	1	1500,505,510, 1495,515,	I	I
					15 U-SCHEIBE	I	233398	I	1	1500,505,510, 1495,515,	I	I
					15 DISTANZSCHEIBE	I	265300	I	2	1500,505,510, 1495,515,	I	I
					16 PLATTE	I	228794	I	1	1500,505,510, 1495,515,	I	I
					17 BOLZEN	I	S 031088	I	6	1500,505,510, 1495,515,	I	I
					18 DICHTUNGSSATZ TYP "BENDIX"	I	229636	I	1	1500,505,510, 1495,515,	I	I
					18 DICHTUNGSSATZ TYP "TECNO DELTA"	I	229629	I	1	1500,505,510, 1495,515,	I	I

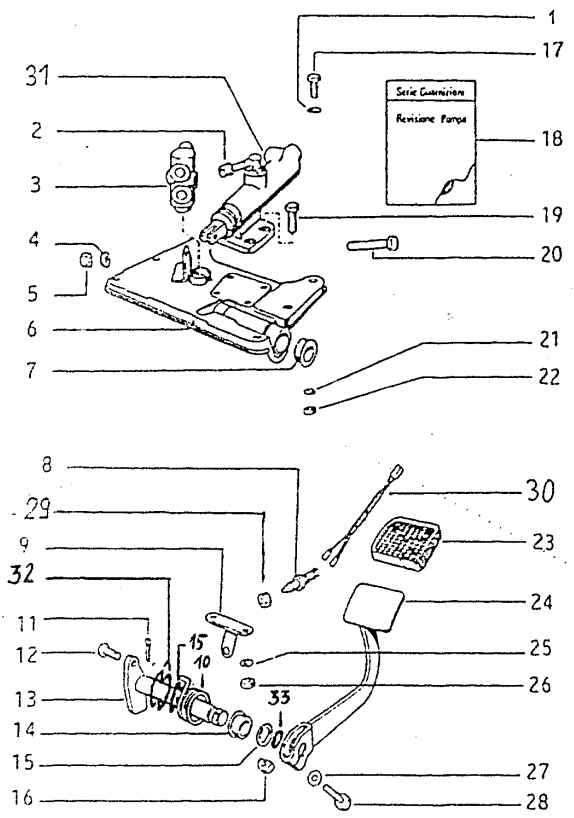

N	I	I	I	I	I	I	I	I	I	I	I	
	ITAFEL 53	BREMSPED.-HAUPTBREMSZYL.-DRUCKREG	SPALTE 13C	I	ABB. BENENNUNG	I	ERSATZTEIL	I	ST	IKENNZIFFER	IBEMERKUNGEN	I

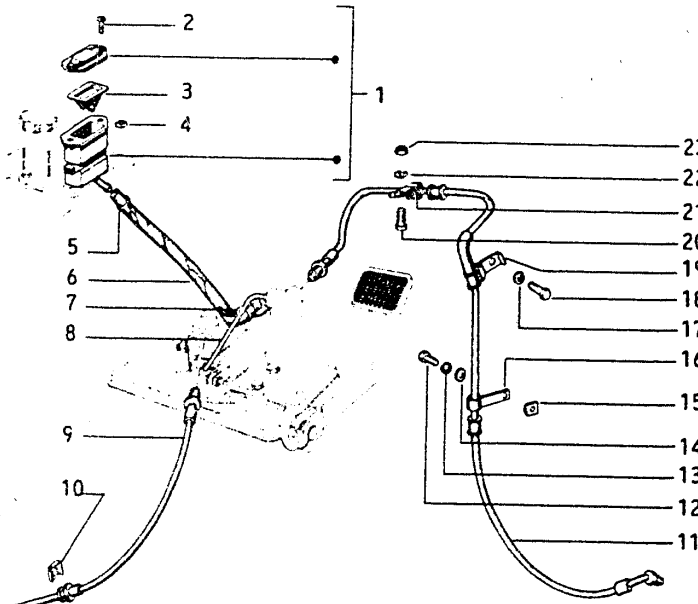
I I I	I ITAFEL 54 BREMSLEITUNGEN-FLUESS.-BEHAELTER	I SPALTE 13D	I IABB. BENENNUNG	I I ERSATZTEIL	I I	I I	I ST IKENNZIFFER	I IBEMERKUNGEN	I I
I		I	I 1 BREMSFLUESSIG-KEITSSBEHAELTER	I 253570	I 1	I 1500,505,510, I 1495,515,	IA: MIT ABB. 2-4. I	I	
I		I 2 SCHRAUBE	I S 015585	I 2	I 1500,505,510, I 1495,515,	I	I		
I		I 3 MEMBRANE	I 253569	I 1	I 1500,505,510, I 1495,515,	I	I		
I		I 4 MUTTER	I S 015285	I 2	I 1500,505,510, I 1495,515,	I	I		
I		I 5 SCHELLE	I 090982	I 1	I 1500,505,510, I 1495,515,	I	I		
I		I 6 BREMSSCHLAUCH	I 228887	I 1	I 1500,505,510, I 1495,515,	I	I		
I		I 6 BREMSSCHLAUCH	I 255482	I 1	I 1500,505,510, I 1515,495,	IB: MONTIERT AB NOVEMBER 1988 I	I		
I		I 7 SCHELLE	I 145298	I 1	I 1500,505,510, I 1495,515,	I	I		
I		I 8 BREMSLEITUNG	I 228854	I 1	I 1500,505,510, I 1495,515,	I	I		
I		I 9 BREMSLEITUNG-HINTERRADBREMSE	I 229728	I 1	I 1500,505,510, I 1495,515,	I	I		
I		I 10 HALTER	I 229727	I 1	I 1500,505,510, I 1495,515,	I	I		
I		I 11 BREMSLEITUNG-VORDERRAD	I 229729	I 1	I 1500,505,510, I 1495,515,	I	I		
I		I 11 BREMSLEITUNG	I 266486	I 1	I 1500,505,510, I 1495,515,	IC: AB SEPTEMBER 1989 I	I		
I		I 12 SCHRAUBE	I S 031086	I 1	I 1500,505,510, I 1495,515,	I	I		
I		I 13 FEDERRING	I S 016406	I 1	I 1500,505,510, I 1495,515,	I	I		
I		I 14 U-SCHEIBE	I S 003056	I 1	I 1500,505,510, I 1495,515,	I	I		
I		I 15 MUTTER	I 251875	I 1	I 1500,505,510, I 1495,515,	I	I		
I		I 16 SCHELLE	I 229343	I 1	I 1500,505,510, I 1495,515,	I	I		
I		I 17 FEDERRING	I S 016406	I 1	I 1500,505,510, I 1495,515,	I	I		
I		I 18 BOLZEN	I S 031088	I 1	I 1500,505,510, I 1495,515,	I	I		
I		I 19 SCHELLE	I 229292	I 1	I 1500,505,510, I 1495,515,	I	I		
I		I 20 BOLZEN	I S 031057	I 1	I 1500,505,510, I 1495,515,	I	I		
I		I 21 SCHELLE	I 229784	I 1	I 1500,505,510, I 1495,515,	I	I		
I	I 22 FEDERRING	I S 016405	I 1	I 1500,505,510, I 1495,515,	I	I			
I	I 23 MUTTER	I S 020105	I 1	I 1500,505,510, I 1495,515,	I	I			

N	I	I	I	I	I	I	I	I	I	I	I										
	SE	T.	R.:	T AB	. BEI	AN-	DES	REMS-	HAL-	ER	ALLE	>29	MON-								
ITAFEL 56			STOSSDAEMPFER - HINTERRAD		SPÄLTE 14B			IABB. BENENNUNG	I ERSATZTEIL	I ST IKENNZIFFER	IBEMERKUNGEN		I	I							
								1 MUTTER	S 020109	1	1500,505,510,	1495,515,									
								2 FEDERRING	S 012539	1	1500,505,510,	1495,515,									
								3 PLATTE	253376	1	1500,505,510,	1495,515,									
								4 PUFFER	178150	1	1500,505,510,	1495,515,									
								5 PUFFER	178149	1	1500,505,510,	1495,515,									
								6 MUTTER	S 020109	1	1500,505,510,	1495,515,									
								7 PLATTE	228450	1	1500,505,510,	1495,515,									
								7 PLATTE	229586	1	1500,505,510,	1495,515,	IA: AB MAI 1989								
								8 SCHRAUBE	S 030103	1	1500,505,510,	1495,515,									
								9 PUFFER	137389	1	1500,505,510,	1495,515,									
								10 STOSSDAEMPFER	229529	1	1500,505,510,	1495,515,									
								11 FEDER	228215	1	1500,505,510,	1495,515,									
								12 FEDERRING	S 016410	1	1500,505,510,	1495,515,									
								13 MUTTER	S 020210	1	1500,505,510,	1495,515,									
								14 BOLZEN	238370	1	1500,505,510,	1495,515,									
								15 SPRENGRING	S 016414	1	1500,505,510,	1495,515,									
								16 MUTTER	S 021214	1	1500,505,510,	1495,515,									
								17 HALTER FUER SCHALTZUEGE	253715	1	1500,505,510,	1495,515,									
								STOSSDAEMPFER- SCHUTZ, PLASTIK	229287	1	1500,505,510,	1495,515,									

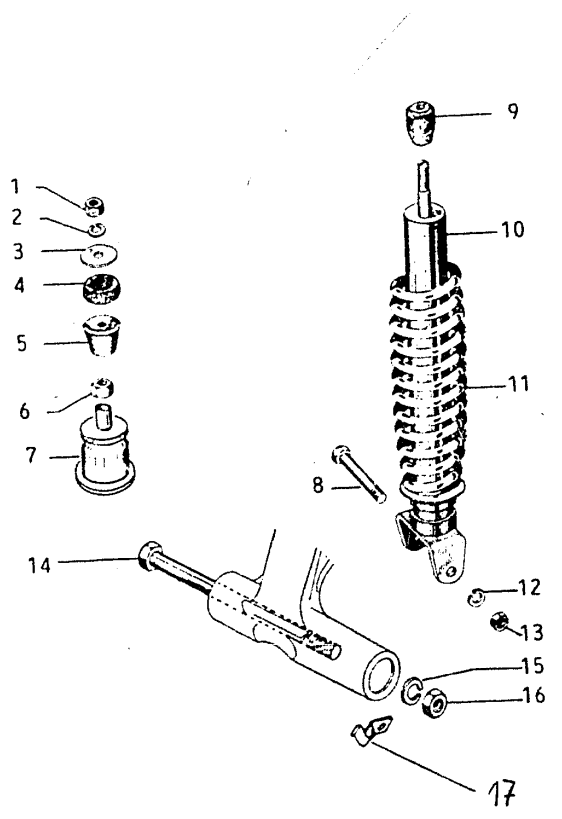

IN	TAFEL 60	ZUENDSCHALTER - LENKERKABELAESTE	SPALTE 16B	IABB. BENENNUNG	ERSATZTEIL	ST	IKENNZIFFER	IBEMERKUNGEN	ITAF
1. 2.				1 KABELAST	252941	1	1500,505,510, 1495,515,		
				2 KABELAST	252726	1	1500,505,510, 1495,515,		
				3 FEDERKLAMMER	253937	1	1500,505,510, 1495,515,		
				4 ZUENDSCHALTER	254494	1	1495,500,510,		
. 6.				4 ZUENDSCHALTER	254493	1	1505,515,		
R:				5 KURZSCHLUSSKNOPF	232204	1	1505,515,		
003551I				FUER FERNSCHALTERI					
006473I									
004085I									

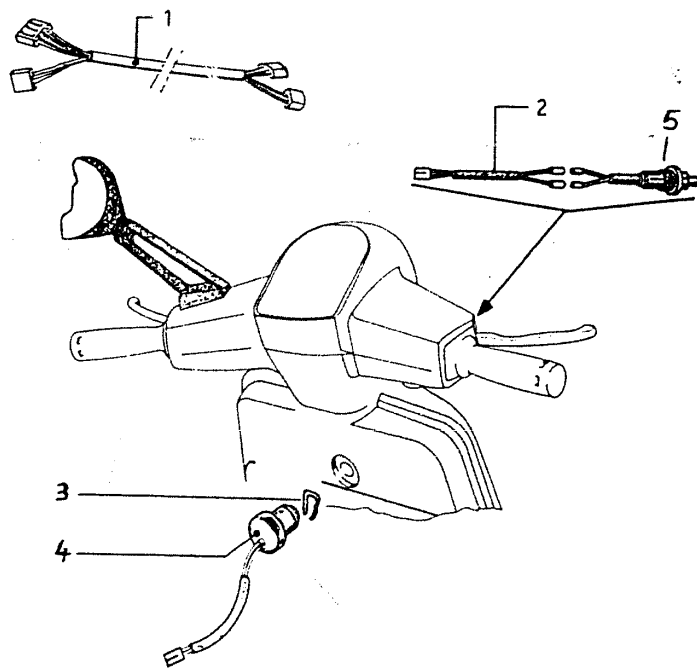

EN	I	I	I	I	I	I	I	I	I	I		
		ITAFEL 62	HUPE-LICHTSCHALTER-BLINKLICHTSCHA	SPALTE 17B	I	ERSATZTEIL	I	ST I	IKENNZIFFER	IBEMERKUNGEN	I	ITA
					I	1 LICHTSCHALTER	I	1	1500,505,510, 1495,515,	IA: MIT ABB. 2,3.	I	I
					I	2 U-SCHEIBE	I	S	003053		I	I
					I	3 SCHRAUBE	I	S	008999		I	I
					I	4 FEDERRING	I	S	016406		I	I
					I	5 MUTTER	I	S	020106		I	I
					I	6 HUPE	I	I	196907		I	I
					I	6 HUPE	I	I	217038		I	I
					I	7 BLINKLICHTSCHALTER	I	I	252128		I	I
					I	7 BLINKLICHTSCHALTER	I	I	252130		I	I
					I		I				I	I
					I		I				I	I
					I		I				I	I
					I		I				I	I
					I		I				I	I
					I		I				I	I
					I		I				I	I
					I		I				I	I
					I		I				I	I
					I		I				I	I
					I		I				I	I
					I		I				I	I
					I		I				I	I
					I		I				I	I
					I		I				I	I
					I		I				I	I
					I		I				I	I
					I		I				I	I
					I		I				I	I
					I		I				I	I
					I		I				I	I
					I		I				I	I
					I		I				I	I
					I		I				I	I
					I		I				I	I
					I		I				I	I
					I		I				I	I
					I		I				I	I
					I		I				I	I
					I		I				I	I
					I		I				I	I
					I		I				I	I
					I		I				I	I
					I		I				I	I
					I		I				I	I
					I		I				I	I
					I		I				I	I
					I		I				I	I
					I		I				I	I
					I		I				I	I
					I		I				I	I
					I		I				I	I
					I		I				I	I
					I		I				I	I
					I		I				I	I
					I		I				I	I
					I		I				I	I
					I		I				I	I
					I		I				I	I
					I		I				I	I
					I		I				I	I
					I		I				I	I
					I		I				I	I
					I		I				I	I
					I		I				I	I
					I		I				I	I
					I		I				I	I
					I		I				I	I
					I		I				I	I
					I		I				I	I
					I		I				I	I
					I		I				I	I
					I		I				I	I
					I		I				I	I
					I		I				I	I
					I		I				I	I
					I		I				I	I
					I		I				I	I
					I		I				I	I
					I		I				I	I
					I		I				I	I
					I		I				I	I
					I		I				I	I
					I		I				I	I
					I		I				I	I
					I		I				I	I
					I		I				I	I
					I		I				I	I

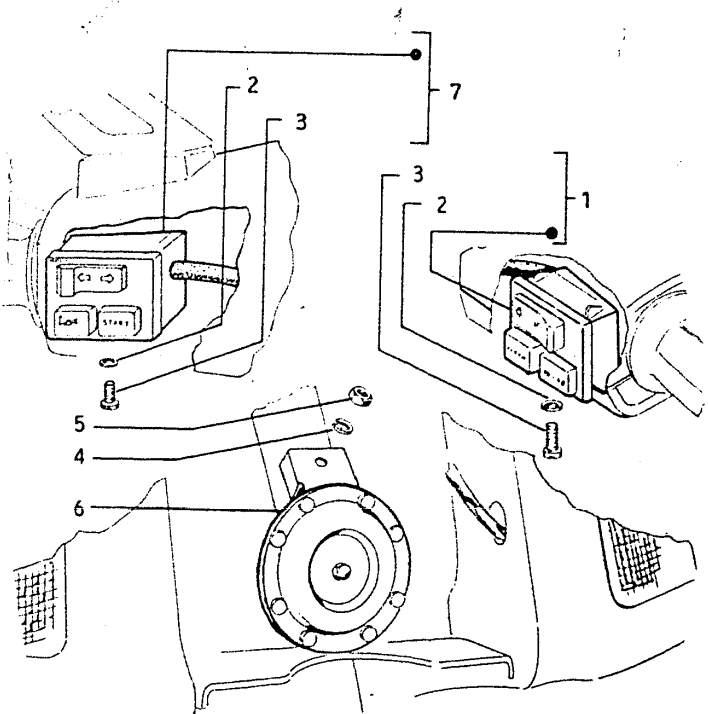

ITAFEL 64







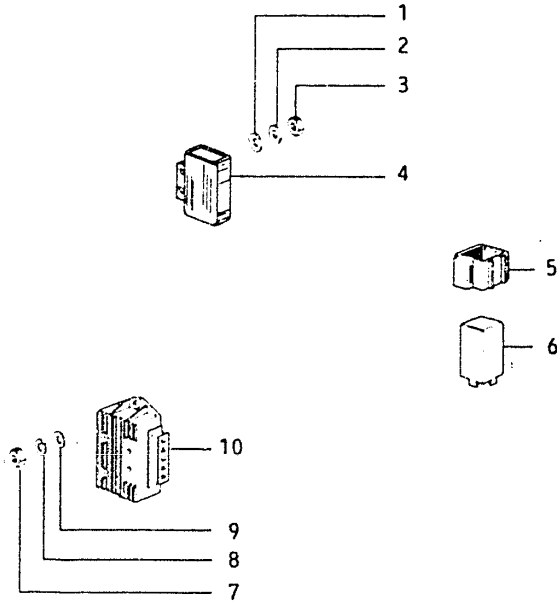

GLEICHRICHTER-REGLER-BLINKGEBER

SPALTE 17D

IABB. BENENNUNG I ERSATZTEIL I ST IKENNZIFFER IBEMERKUNGEN

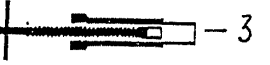

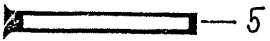
IABB. BENENNUNG	I ERSATZTEIL	I ST	IKENNZIFFER	IBEMERKUNGEN
1 U-SCHEIBE	I S 003055	I 2	1500,510,	I
1 U - SCHEIBE	I S 006078	I 2	1495,	I
2 FEDERRING	I S 016405	I 2	1495,500,510,	I
3 MUTTER	I S 020105	I 2	1495,500,510,	I
4 GLEICHRICHTER	I 252601	I 1	1495,500,510,	I
5 ELAST.HALTER	I 164343	I 1	1500,505,510,	I
6 BLINKGEBER	I 197283	I 1	1495,515,	I
7 MUTTER	I S 020105	I 2	1500,505,510,	I
8 FEDERRING	I S 016405	I 2	1495,515,	I
9 U-SCHEIBE	I S 006078	I 2	1500,505,510,	I
10 ELEKTRON. REGLER	I 252025	I 1	1495,515,	I
10 ELEKTRON. REGLER	I 230824	I 1	1505,515,	I

TAFEL 67		SPEZIALWERKZEUG	SPALTE 18C	IABB. BENENNUNG	ERSATZTEIL	ST	IKENNZIFFER	IBEMERKUNGEN
2,3.		- 1		1 ABZIEHER F. LAGERI	19.1.14499	1	1500,505,510,	
				2 ZANGE FUER	119.1.17104	1	1500,505,510,	
				SICHERUNGSRINGE		1	1515,495,	
				3 GERAET ZUM EINBAU	119.1.18119	1	1500,505,510,	
				DER WELLEN UND		1	1515,495,	
				ACHSEN		1		
				4 HEIZPLATTE	119.1.19978	1	1500,505,510,	
		- 2		5 GERAET ZUM AUSBAU	119.1.20004	1	1500,505,510,	
				DES OBEREN LAUF-		1	1515,495,	
				RINGES D. STEUER-		1		
				ROHRLAGERS		1		
				6 WERKZEUG ZUR	119.1.20021	1	1500,505,510,	
				REVISION DER		1	1515,495,	
				VORDERRADAUF-		1		
				HAENGUNG		1		
		- 3		7 SCHLAGDORNE FUER	119.1.20036	1	1500,505,510,	
				NADELHUELSEN		1	1515,495,	
				7 SCHLAGDORNE FUER	119.1.20037	1	1500,505,510,	
				NADELHUELSEN		1	1515,495,	
				7 SCHLAGDORNE FUER	119.1.20038	1	1500,505,510,	
				NADELHUELSEN		1	1515,495,	
				8 SCHLUESSEL FUER	119.1.20055	1	1500,505,510,	
				OBERE NUTMUTTER		1	1515,495,	
				DES STEUERROHRES		1		
		- 5		9 WERKZEUG ZUM VER-	119.1.20057	1	1500,505,510,	
				STEMMEN DER		1	1515,495,	
				SCHUTZKAPPE DES		1		
				ANLASSERRITZELS		1		
				10 PRUEFLAGER FUER	119.1.20074	1	1500,505,510,	
				KURBELWELLE		1	1515,495,	
				11 SPERRGERAET FUER	119.1.20095	1	1500,505,510,	
				SCHWUNGRAD		1	1515,495,	
				12 AUFZIEHDORN FUER	119.1.20148	1	1500,505,510,	
				DICHTRINGE DES		1	1515,495,	
				HAUPTBREMSZYLIN-		1		
				DERS UND DES		1		
				VORD. BREMS-		1		
				ZYLINDERS		1		
				13 AUFZIEHDORN FUER	119.1.20149	1	1500,505,510,	
				DICHTUNGEN DES		1	1515,495,	
				HINTEREN BREMS-		1		
				ZYLINDERS		1		

ITAFEL 69	SPEZIALWERKZEUG	SPALTE 18E	ITAFEL 69	IBEMERKUNGEN
			28 SPERRGERAET FUER KUPPLUNG	1 1500,505,510, 1515,495,
			29 SCHLAGDORNE FUER NADELHUELSEN	1 1500,505,510, 1515,495,
			30 WERKZEUG ZUM TRENNEN DER GEHAEUSEHAELFTEN	1 1500,505,510, 1515,495,
			31 ABZIEHER FUER SCHWUNGRAD	1 1500,505,510, 1515,495,
			32 DISTANZSTUECK	1 1500,505,510, 1515,495,
			33 FUEHLERLEHRE ZUR PRUEFUNG DES AXIALSPIELES	1 1500,505,510, 1515,495,

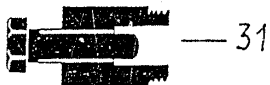

E R S A T Z T E I L - N U M M E R N - V E R Z E I C H N I S																						
ITEILE-NR.	SALTE	TEILE-NR.	SALTE	TEILE-NR.	SALTE	TEILE-NR.	SALTE	TEILE-NR.	SALTE													
I	i	I	I	I	I	I	I	I	I	I												
I	14246	I	5D	I	082934	I	5F	I	132041	I	2F	I	157103	I	2B	I	179124	I	6A	I		
I	93233	I	2E	I	083806	I	3A	I	132042	I	2F	I	157716	I	8A	I	179292	I	10A	I		
I	97773	I	2D	I	084262	I	9B	I	132370	I	5G	I	158962	I	2D	I	179506	I	4C	I		
I	97804	I	2D	I	085285	I	5G	I	133068	I	2D	I	159347	I	7A	I	179507	I	6A	I		
I	000097	I	2E	I	085291	I	5F	I	133157	I	2C	I	159853	I	3B	I	179508	I	6A	I		
I	000267	I	2E	I	085293	I	5F	I	133184	I	2C	I	159873	I	7D	I	179510	I	6A	I		
I	000397	I	3F	3F	I	085294	I	5F	I	133223	I	5A	I	159905	I	3B	I	179511	I	6A	I	
I	002457	I	3D	I	085299	I	5G	I	133238	I	5D	I	163778	I	8F	I	179514	I	6A	I		
I	002612	I	5D	I	085304	I	5G	I	133256	I	5D	I	164343	I	17D	I	179516	I	6B	I		
I	002613	I	5D	I	085418	I	5G	I	133578	I	5D	I	164634	I	16A	I	179569	I	12D	I		
I	014457	I	3A	I	085914	I	7A	12C	I	133918	I	2F	I	165260	I	5A	I	179574	I	12D	I	
I	017781	I	3A	I	087975	I	5D	I	134865	I	5A	I	165415	I	3G	I	179575	I	12D	12D	I	
I	019264	I	11B	I	089858	I	3A	I	134914	I	5A	I	165416	I	3G	I	181746	I	17C	I	I	
I	019301	I	3A	I	090527	I	3E	I	136340	I	2F	I	165417	I	3G	I	185365	I	3E	I	I	
I	020375	I	2E	I	090541	I	15B	I	137334	I	3D	I	165418	I	3G	I	188774	I	3E	I	I	
I	021868	I	3B	3B	I	090982	I	13D	I	137389	I	14B	I	166366	I	4A	4B	I	188776	I	3E	I
I	022313	I	2E	I	092395	I	5F	I	138345	I	3F	I	167302	I	3E	I	188778	I	3E	I	I	
I	022821	I	3B	3B	I	092410	I	5F	5F	I	138393	I	3G	I	174085	I	14A	I	189058	I	8E	I
I	026018	I	5G	I	092667	I	11B	I	138865	I	3E	I	174088	I	14A	I	189130	I	3E	I	I	
I	029465	I	4D	I	093745	I	3B	I	139100	I	3D	I	174128	I	12A	I	190953	I	5G	I	I	
I	030209	I	3D	I	093994	I	5G	I	139466	I	13A	I	174129	I	12A	I	191002	I	10C	I	I	
I	032005	I	3B	I	094425	I	3B	I	140528	I	7C	I	174312	I	3C	I	191695	I	2F	I	I	
I	038477	I	3B	I	094743	I	3B	I	141589	I	4D	I	174514	I	3D	I	191962	I	18A	I	I	
I	046612	I	3E	I	094780	I	3B	I	141590	I	4D	I	174515	I	3D	I	193206	I	7D	I	I	
I	046613	I	3E	I	097248	I	9B	I	145298	I	13D	5C	I	174735	I	3D	I	193870	I	5G	I	I
I	046740	I	3A	I	097645	I	5F	I	146086	I	5B	I	174825	I	3D	I	193988	I	5G	I	I	
I	047162	I	3F	I	097984	I	3A	I	146087	I	5B	I	176048	I	15B	I	194423	I	7A	I	I	
I	047218	I	3C	I	101481	I	10D	10E	I	146129	I	3C	I	176166	I	9C	I	194424	I	7A	I	I
I	050100	I	3A	I	104294	I	9A	I	146504	I	9B	I	177072	I	10D	10E	I	194517	I	5G	I	I
I	050721	I	3B	I	104296	I	9A	I	148570	I	3C	I	177147	I	10D	10D 10E	I	194518	I	5G	I	I
I	055986	I	11B	I	106956	I	3C	I	150044	I	5G	I	177148	I	10D	10E	I	194585	I	3B	I	I
I	055989	I	11B	I	112793	I	3D	I	150049	I	5G	I	177408	I	11C	I	195556	I	8C	I	I	
I	056641	I	11B	I	113010	I	5G	I	150082	I	3B	I	177414	I	12C	I	196486	I	10A	I	I	
I	056649	I	7D	I	113059	I	5B	I	150104	I	3B	I	177436	I	12A	I	196549	I	4A	4B	I	
I	058364	I	5D	I	113060	I	5D	I	150166	I	5G	I	177442	I	12C	I	196780	I	13C	I	I	
I	059109	I	3B	I	113076	I	5D	I	150656	I	2B	I	177443	I	12C	I	196868	I	9A	9B	I	
I	059369	I	3B	I	113291	I	5D	I	150869	I	2F	I	177445	I	11C	I	196907	I	17B	I	I	
I	059388	I	3B	I	113526	I	3D	I	151805	I	2E	I	177451	I	11C	I	197283	I	17D	I	I	
I	059407	I	3E	I	113995	I	3A	I	152805	I	3G	I	177494	I	12A	I	197572	I	9A	I	I	
I	059408	I	3E	I	118058	I	3G	I	153024	I	11B	I	177508	I	12A	I	197574	I	9A	9B	I	
I	071671	I	4D	I	119219	I	11C	I	153198	I	15A	15B	I	177521	I	11C	I	197983	I	12C	I	I
I	077023	I	11B	I	119279	I	15A	I	154546	I	2C	I	177609	I	12C	I	198015	I	7A	I	I	
I	077024	I	11B	I	119813	I	2F	I	154564	I	2C	I	177610	I	12C	I	198450	I	2D	I	I	
I	077370	I	3D	I	119975	I	18B	I	154698	I	11B	I	177671	I	12A	I	198488	I	2G	I	I	
I	077371	I	3D	I	129953	I	17A	I	154791	I	10E	I	178000	I	3B	I	198513	I	11C	I	I	
I	077372	I	3D	I	130143	I	7C	I	154792	I	5B	I	178051	I	11C	I	198686	I	4D	I	I	
I	078307	I	3H	3H 4C	I	130291	I	7C	I	156291	I	2F	I	178149	I	14B	I	198751	I	2G	I	I
I	078853	I	3D	I	130977	I	2F	I	156292	I	2F	I	178150	I	14B	I	199055	I	4D	I	I	
I	082931	I	5F	I	131845	I	5G	I	156293	I	2G	I	178838	I	3C	I	199091	I	12D	I	I	
I	082933	I	5F	I	132040	I	2F	I	156401	I	15A	I	179117	I	6A	I	199190	I	8A	I	I	
I	i	I	I	I	I	I	I	I	I	I	I	I	I	I	I	I	I	I	I	I	I	
I	i	I	I	I	I	I	I	I	I	I	I	I	I	I	I	I	I	I	I	I	I	

ERSATZTEIL - NUMMERN - VERZEICHNIS

ITEILE-NR.	SPALTE	TEILE-NR.	SPALTE	TEILE-NR.	SPALTE	TEILE-NR.	SPALTE	TEILE-NR.	SPALTE
I 199664	I 5E	I 228506	I 8F	I 228834	I 7B 12A	I 229543	I 12A	I 238677	I 2B
I 199671	I 5G	I 228509	I 8F	I 228835	I 7B	I 229547	I 12A	I 238710	I 2B
I 199803	I 3E	I 228514	I 8F	I 228841	I 7A 12B	I 229554	I 10B	I 238799	I 2B
I 199804	I 3E	I 228515	I 8F	I 228854	I 13D	I 229570	I 10B	I 238821	I 2G
I 212646	I 7A	I 228517	I 8F	I 228857	I 13B	I 229586	I 14B	I 238825	I 2F
I 214772	I 13B	I 228518	I 8G	I 228861	I 12B	I 229613	I 12A	I 238838	I 2B
I 215809	I 3A	I 228522	I 10C	I 228862	I 12B	I 229614	I 7B	I 238848	I 2C
I 216895	I 18A	I 228529	I 10D	I 228863	I 12B	I 229629	I 13B	I 238855	I 2B
I 217038	I 17B	I 228531	I 10E	I 228866	I 12B	I 229633	I 7A	I 238873	I 5A
I 217280	I 15B	I 228535	I 10D	I 228887	I 13D	I 229634	I 12B	I 238875	I 5A
I 217421	I 6A	I 228536	I 10E	I 228889	I 12C	I 229636	I 13B	I 238898	I 5B
I 218677	I 9A	I 228537	I 10D	I 228901	I 12D	I 229644	I 8F	I 238920	I 2A
I 218721	I 4A	I 228538	I 10E	I 228903	I 12D	I 229697	I 7A	I 238930	I 2A
I 218812	I 18A	I 228539	I 10D	I 228908	I 15B	I 229723	I 11A	I 238932	I 5A
I 218823	I 18A	I 228541	I 10D 10E	I 228933	I 8G	I 229726	I 12A	I 238959	I 2E
I 218824	I 18A	I 228559	I 14A	I 228948	I 10C	I 229727	I 13D	I 238969	I 2C
I 218824	I 18A	I 228572	I 10B	I 229114	I 7A	I 229728	I 13D	I 239017	I 5D
I 219363	I 9A	I 228573	I 10C	I 229144	I 15A	I 229729	I 13D	I 239042	I 5B
I 221612	I 5A	I 228585	I 16A	I 229163	I 15B	I 229732	I 12A	I 239044	I 5B
I 221614	I 5A	I 228598	I 8F	I 229173	I 10E	I 229733	I 11C	I 239049	I 5D
I 223225	I 3G	I 228601	I 8F	I 229185	I 15A	I 229784	I 13D	I 239089	I 5G
I 223226	I 3G	I 228611	I 10B	I 229212	I 7A	I 229795	I 10B	I 239100	I 2F
I 223229	I 3G	I 228612	I 10B	I 229214	I 12B	I 229872	I 3A	I 239101	I 2F
I 223231	I 3G	I 228614	I 10B	I 229218	I 12D	I 230824	I 17D	I 239102	I 2F
I 223232	I 3G	I 228615	I 10B	I 229231	I 8F	I 230872	I 8A	I 239149	I 2C
I 223233	I 3G	I 228627	I 14A	I 229251	I 7B 12A	I 231095	I 4A	I 239150	I 2C
I 223234	I 3G	I 228628	I 14A	I 229254	I 13C		I 4B	I 239151	I 2C
I 223604	I 2B	I 228633	I 14A	I 229261	I 13B	I 231215	I 17A	I 239152	I 2C
I 225170	I 6A	I 228634	I 14A	I 229275	I 13B	I 231571	I 4D	I 239153	I 2B 2B 3F
I 225171	I 6A	I 228635	I 14A	I 229287	I 14B	I 232204	I 10E 16B	I 239169	I 5D
I 225190	I 6A	I 228636	I 14A	I 229292	I 13D	I 233120	I 9C	I 239175	I 5D
I 225191	I 6A	I 228637	I 11C	I 229343	I 13D	I 233121	I 9C	I 239217	I 7D
I 225557	I 10A	I 228661	I 13A	I 229357	I 16A	I 233122	I 9C	I 239265	I 5B
I 225563	I 6C	I 228662	I 13A	I 229358	I 16A	I 233255	I 17A	I 239321	I 2F
I 225572	I 6C	I 228663	I 13A	I 229365	I 15A	I 233260	I 17A	I 239322	I 2F
I 225811	I 6A	I 228781	I 13B	I 229405	I 7A	I 233398	I 13B	I 239323	I 2G
I 225812	I 6A	I 228785	I 13B 13B	I 229414	I 7A 12B	I 233871	I 4A	I 239327	I 2G
I 225878	I 6A	I 228786	I 13B	I 229451	I 7B	I 235646	I 3B	I 239328	I 2F
I 225879	I 6A	I 228789	I 13C	I 229459	I 7B	I 235747	I 5D	I 239348	I 5B SF
I 226156	I 10B 11B	I 228793	I 13C	I 229465	I 10B	I 235908	I 3G	I 239367	I 5B
I 226208	I 11B	I 228794	I 13B	I 229482	I 10B	I 236213	I 5A	I 239539	I 2A
I 226274	I 15A	I 228807	I 13B	I 229483	I 10B	I 236222	I 3D	I 239547	I 5B
I 226285	I 15B	I 228812	I 12D	I 229497	I 10B	I 236223	I 3D	I 239567	I 2A
I 228164	I 16A	I 228813	I 12D	I 229498	I 10B	I 236402	I 5A	I 239594	I 2D
I 228215	I 14B	I 228820	I 12C	I 229506	I 13B	I 238370	I 14B	I 239689	I 5B SF
I 228229	I 13A	I 228828	I 7B	I 229516	I 12B	I 238587	I 2B	I 239778	I 7C
I 228230	I 13A	I 228830	I 7B	I 229522	I 13B	I 238594	I 2B	I 239790	I 2D
I 228256	I 14A	I 228831	I 7B	I 229526	I 7B 12A	I 238595	I 2B	I 240997	I 6A
I 228450	I 14B	I 228832	I 7B	I 229529	I 14B	I 238599	I 7C	I 241004	I 3C
I 228505	I 8F	I 228833	I 7B	I 229536	I 7B	I 238675	I 7C	I 241590	I 2E

||||| M18 |||||

ERSATZTEIL - NUMMERN - VERZEICHNIS

ITEILE-NR.	SPALTE	TEILE-NR.	SPALTE	TEILE-NR.	SPALTE	TEILE-NR.	SPALTE	TEILE-NR.	SPALTE
I	i	I	I	I	I	I	I	I	I
I	i	I	I	I	I	I	I	I	I
I	i	I	I	I	I	I	I	I	I
I S 006642	I 3D	I S 015727	I 8D	I S 030073	I 13C	I 119.1.30627	I 18D	I	I
I S 006647	I 3G	I S 015737	I 2D 4A 4B	I S 030074	I 14A	I 119.1.31729	I 18E	I	I
I S 006662	I 2D	I S 015861	I 3C	I S 030076	I 13C	I 119.1.33971	I 18E	I	I
I S 006708	I 3A 5A	I S 015911	I 8B	I S 030103	I 14B	I 119.1.38886	I 18E	I	I
I S 006721	I 3C	I S 015946	I 3H 4C 4C	I S 030251	I 5D	I 119.1.48564	I 18E	I	I
I S 006731	I 11C	I	I 18A	I S 030262	I 5D	I 119.1.60007	I 18E	I	I
I S 006964	I 5A	I S 015947	I 6C	I S 030280	I 3F	I 119.1.60824	I 18E	I	I
I S 006965	I 4A 4B	I S 015994	I 16A	I S 030283	I 2D	I	I	I	I
I S 006968	I 2D 6C 7D	I S 016305	I 3D	I S 031009	I 7D	I	I	I	I
I S 006977	I 2D 3H	I S 016403	I 18A	I S 031027	I 17A	I	I	I	I
I S 007608	I 12D	I S 016404	I 5B 6C 17C	I S 031056	I 12A	I	I	I	I
I S 008080	I 2D	I S 016405	I 4D 5D 6A	I S 031057	I 13D	I	I	I	I
I S 008108	I 8A 8C 8E	I	I 12A 13D 17D	I S 031084	I 7B	I	I	I	I
I S 008265	I 8C 9A	I S 016406	I 3A 4C 4D	I S 031086	I 6B 11A 13D	I	I	I	I
I S 008339	I 5A	I	I 6A 6B 7B	I	I 18A	I	I	I	I
I S 008375	I 8E	I S 016407	I 2C 2C 2C	I S 031087	I 8F	I	I	I	I
I S 008451	I 8E 8E 8G	I	I 2C 3F 13C	I S 031088	I 9C 12A 13B	I	I	I	I
I	I 9A	I S 016408	I 3C 6A 7A	I	I 13D	I	I	I	I
I S 008455	I 8B 8B 8C	I	I 7B 7D	I S 031091	I 6A 12D	I	I	I	I
I S 008457	I 8A 8A	I S 016409	I 5B	I S 031092	I 11A	I	I	I	I
I S 008987	I 8F	I S 016410	I 7C 14B	I S 031119	I 7B 8G 8G	I	I	I	I
I S 008999	I 17B	I S 016414	I 14B	I	I 9B	I	I	I	I
I S 009000	I 8C	I S 016612	I 3D	I 119.1.14499	I 18C	I	I	I	I
I S 009101	I 3G	I S 016631	I 2C 2C 2C	I 119.1.17104	I 18C	I	I	I	I
I S 010028	I 5B	I	I 2C 2C	I 119.1.18119	I 18C	I	I	I	I
I S 012533	I 12A	I S 018534	I 10C	I 119.1.19978	I 18C	I	I	I	I
I S 012535	I 14A	I S 018605	I 4D	I 119.1.20004	I 18C	I	I	I	I
I S 012539	I 14B	I S 018610	I 8A	I 119.1.20021	I 18C	I	I	I	I
I S 012555	I 2E	I S 020003	I 18A	I 119.1.20036	I 18C	I	I	I	I
I S 012787	I 12C	I S 020005	I 4D	I 119.1.20037	I 18C	I	I	I	I
I S 012789	I 7A	I S 020006	I 9C 13C	I 119.1.20038	I 18C	I	I	I	I
I S 013010	I 3E	I S 020007	I 2C 2C 2C	I 119.1.20055	I 18C	I	I	I	I
I S 013762	I 5B	I	I 2C	I 119.1.20057	I 13C	I	I	I	I
I S 013763	I 8B 17A	I S 020008	I 2C 3C	I 119.1.20074	I 18C	I	I	I	I
I S 013769	I 17C	I S 020104	I 8E 17C	I 119.1.20095	I 18C	I	I	I	I
I S 013776	I 2C	I S 020105	I 3E 6A 13D	I 119.1.20148	I 18C	I	I	I	I
I S 013777	I 9C 13B	I	I 17D 17D	I 119.1.20149	I 18C	I	I	I	I
I S 013836	I 16A	I S 020106	I 4D 6A 11A	I 119.1.20322	I 18D	I	I	I	I
I S 013869	I 10B	I	I 12D 17B 18A	I 119.1.20781	I 18D	I	I	I	I
I S 013880	I 11A	I S 020107	I 3F 13C	I 119.1.20842	I 18D	I	I	I	I
I S 013950	I 8E	I S 020108	I 6A 7A 7D	I 119.1.21071	I 18D	I	I	I	I
I S 014743	I 5D	I	I 7D 12C 13A	I 119.1.21330	I 18D	I	I	I	I
I S 015231	I 3D	I S 020109	I 14B 14B	I 119.1.21467	I 18D	I	I	I	I
I S 015285	I 13D	I S 020207	I 15A	I 119.1.22465	I 18D	I	I	I	I
I S 015507	I 13C	I S 020210	I 14B	I 119.1.22480	I 18D	I	I	I	I
I S 015522	I 2D	I S 021112	I 2E	I 119.1.23589	I 18D	I	I	I	I
I S 015523	I 3H	I S 021114	I 12C	I 119.1.23638	I 18D	I	I	I	I
I S 015568	I 12A	I S 021210	I 14A	I 119.1.25095	I 18D	I	I	I	I
I S 015585	I 4A 4B 13D	I S 021214	I 14B	I 119.1.25127	I 18D	I	I	I	I
I S 015597	I 4D 10C	I S 030050	I 3A	I 119.1.27338	I 18D	I	I	I	I
I	i	I	I	I	I	I	I	I	I
I	i	I	I	I	I	I	I	I	I

||||| N18 |||||